

VORTEX 19M

LEDING



▲ PRODUCT INTRODUCTION

VORTEX 19M is a new generation of excellent moving wash with RGBL LED source, optical Angle 3.5-60°, equipped with HSIC intelligent color mixing system, can quickly modulate any desired color, can be continuously adjusted between 1800K to 10000K, pixel control function, can achieve gorgeous dynamic effect, high-precision and high-tech CCS intelligent color management system for auto color calibration, it is an ideal choice for concerts, touring show, events, as well as rental markets.

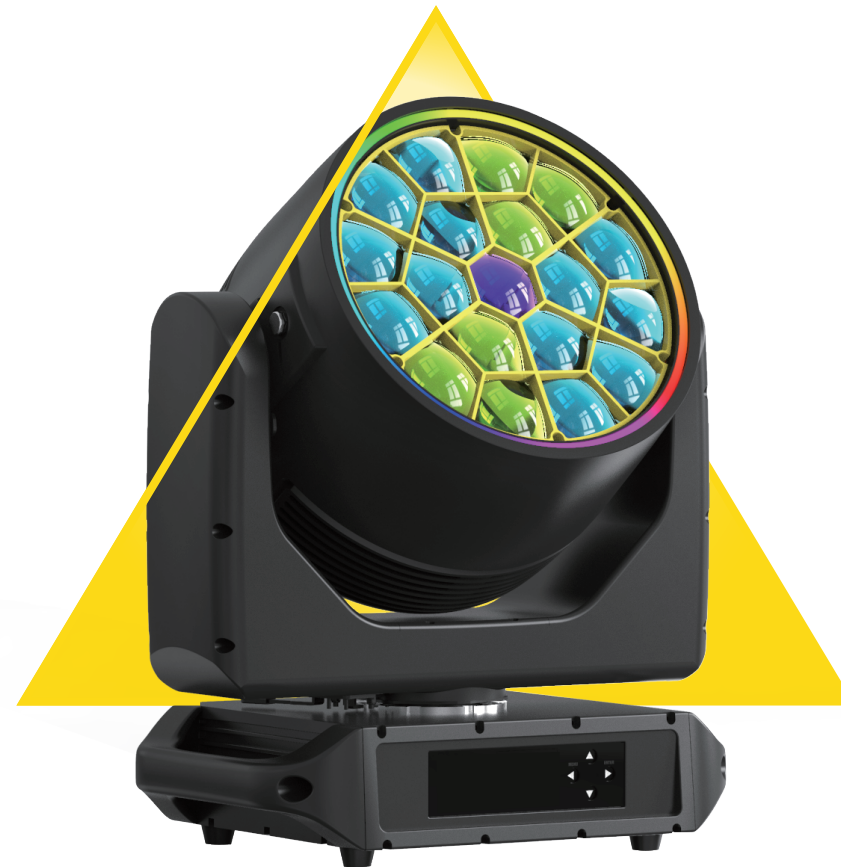

▲ ILLUMINANCE AT DISTANNXE

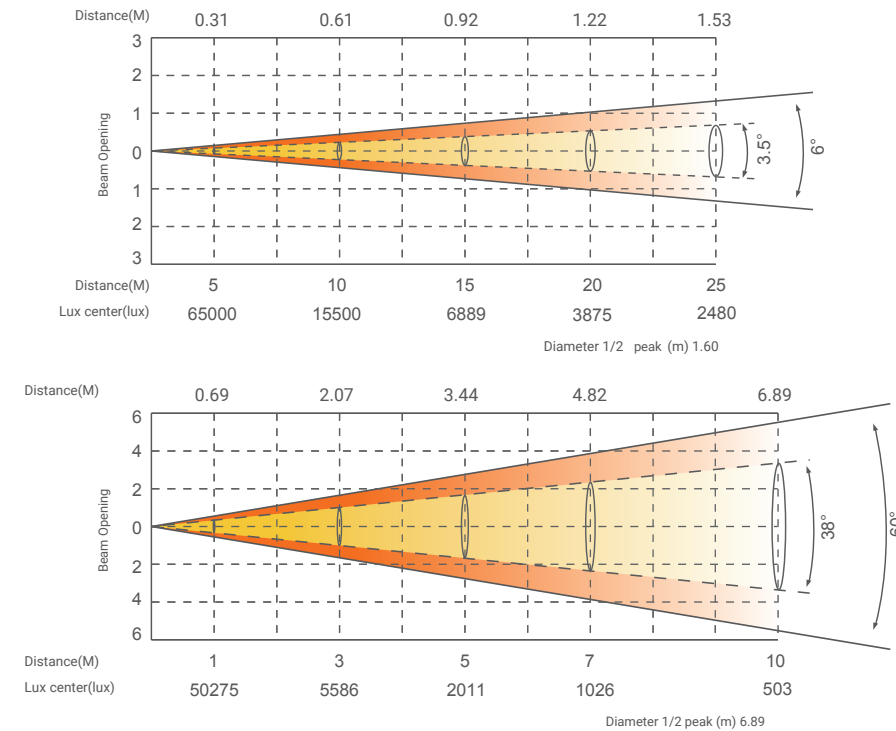

▲ PRODUCT PARAMETERS

Optical system

Light source	50Wx19pcs RGBL LED+LED ring + Double Masks Effect
Angle	3.5°-60°
Illuminance	5m@65000lx, 3.5°
Luminous flux	13000lm

Control System

Pan/Tilt rotation	630°/220°(8-16bit)
Dimmer	0-100% 24Bit
Cooling	Forced Convection
Control	DMX512, RDM, ARTNET, SACN, BT, NFC, W-DMX (optional)

Certification

CE

Appearance

Size	420x316x480mm
Weight	21.55KG
Casing	Magnalium and Di e-cast
Color	Black

Electrical Specs

Voltage	100-240VAC,50/60Hz
Max.Power	1000W
Power Connection	Seetronic power input and output
Signal socket	3pin or 5pin in and out, RJ45 in and out,USB-C

Work Environment

Ambient Temp	-20° -45°
IP Rated	IP66

▲ ILLUMINANCE AT DISTANNXE

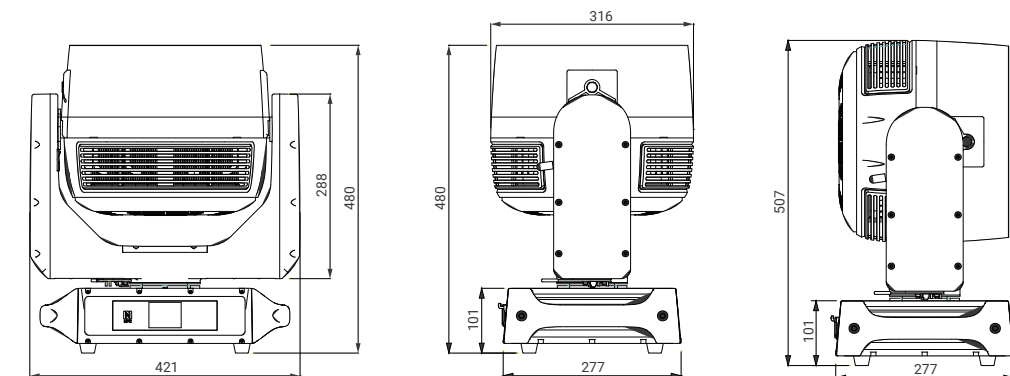

▲ ILLUMINANCE AT DISTANNXE