

# D-BOLT C

## ● PRODUCT INTRODUCTION



## ● PRODUCT PARAMETERS

Main Source: 2x 400W RGBLA LEDs

Secondary Source: 2x LED stripes, each with 24x 2W RGB LEDs

Colour Temperature: 1750-20000K

CRI Ra: 96 @ 2500K and 93 @ 20000K

Brightness: 40660 lumens (156 lumens/watt); 905 lux @ 5m

Beam Angle: 50 degrees (87 degrees field angle)

Lens: interchangeable magnetic lens for standard blinder effect or fresnel effect

Dimmer: 0-100%

Strobe: 0-20Hz

Control Protocols: DMX512A, RDM ANSI E1.20

Control Segments: 2 (main source) and 32 (secondary source)

Tilt Movement: 0-40 degrees each head, 0-360 degrees the entire fixture (manual adjustment)

Max. Power Consumption: 700W

Dimensions: 495 x 299 x 199 mm

Weight: 10 Kg

IP Grade: IP65

Rigging: 1x omega clamp and integrated connectors on left / right / up / down

# D-BOLT C



## DIMENSIONS

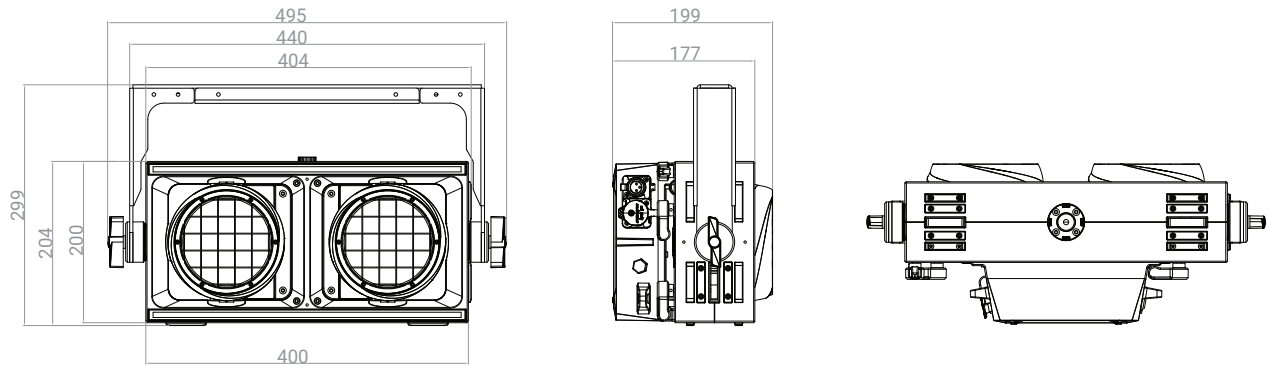

## ACCESSORIES



Yoke 2.2



Floor Extension



Rigging Bracket G2



Floor Bracket



Fresnel Lens