

ECLIPSE 40 C4

USER MANUAL

1 PRODUCT

1.1 TECHNICAL SPECIFICATIONS

Type	ECLIPSE 40 C4
LED colors	40W RGBW LED
Power	40W
Voltage Range	AC100~240V,50/60Hz
Protection	IP20
Operation Temperature	0°C~45°C
Dimensions	291x107x228mm
Weight	1.7kg

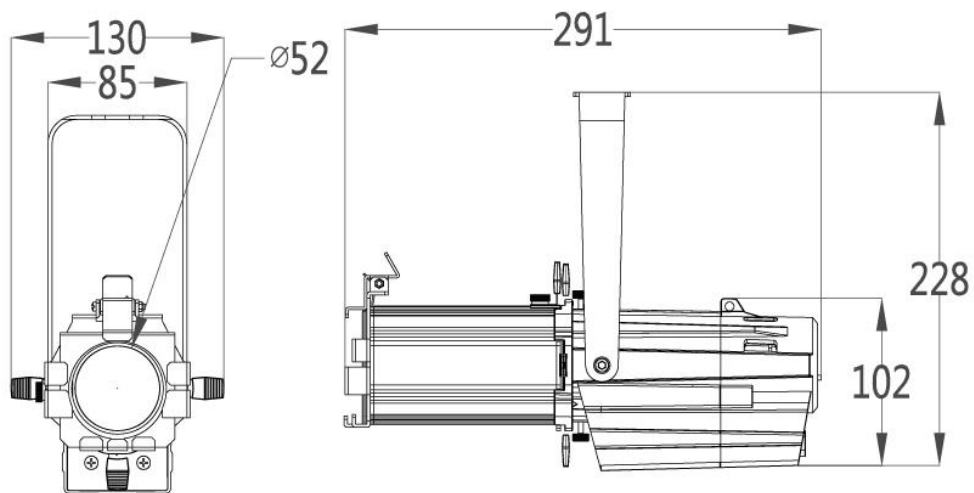
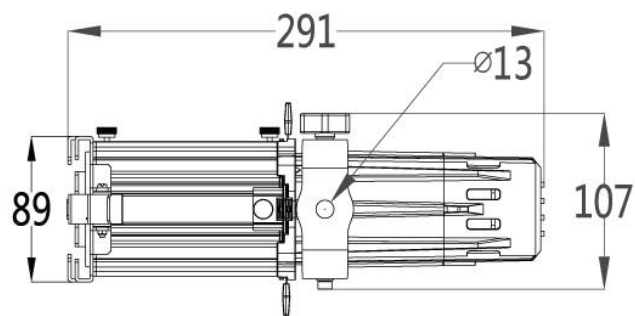

1.2 Safety Notes

IMPORTANT

- This product must be installed by a qualified professional.
- In order to maintain this condition and to ensure a safe operation, it is absolutely necessary for the user to follow the safety instructions and warning notes
- The manufacturer will not accept liability for any resulting damages caused by the non-observance of this manual or any unauthorized modification to the device.

CAUTION!

- Make sure that the available voltage is not higher than stated on the rear panel.
- Do not touch the power cables if your hands are wet.
- The earth wire must always be connected to the ground. Therefore it is essential to connect the yellow/green conductor to earth.
- Make sure that the power-cord is never crimped or damaged by sharp edges. Check the device and the power-cord from time to time. The electric connection, repairs and servicing must be carried out by a qualified employee.
- Always disconnect power input cable to completely remove power from unit when not in use or before cleaning or servicing the fixture.
- Do not switch the fixture on and off in short intervals as this would reduce the lamp's life.
- Do not touch the device's housing bare hands during its operation (housing becomes hot)! The surface of the product's casing can reach up to 70° C (158° F) during operation. Avoid contact by persons and materials. Do not install the product in a location where there is a risk of accidental contact. Allow the product to cool for at least 10 minutes before handling.
- For replacement use lamps and fuses of same type and rating only.
- Please protect the fixture and avoid destroy during transport and installation. If there is any damage to the coating, the shell may be corroded.
- When hanging lamps and lanterns, it is necessary to verify that facilities and hooks can bear at least 10 times the weight of lamps and lanterns.
- Fix the safety rope at the correct holes only. Only operate the fixture after having checked that the housing is firmly closed and all screws are tightly fastened.
- The maximum ambient temperature 45°C must never be exceeded. Do not operate the product if the ambient temperature (Ta) exceeds 45° C (115° F).

Electrical Warning

- The light source contained in this luminaire shall only be replaced by the manufacturer or his service agent or a similar qualified person

2 INSTALLATION

2.1 MOUNTING

UPRIGHT

- ◆ For overhead use, always install a safety cable that can hold at least 10 times the weight of the fixture.
- ◆ For overhead installation, the fixture must be always secured with a safety wire that can bear at least 10 times the weight of the fixture; Secure the fixture with a safety cable through the rear safety eye as shown.
- ◆ Ensure that the structure (truss) to which you are attaching the fixture is secure

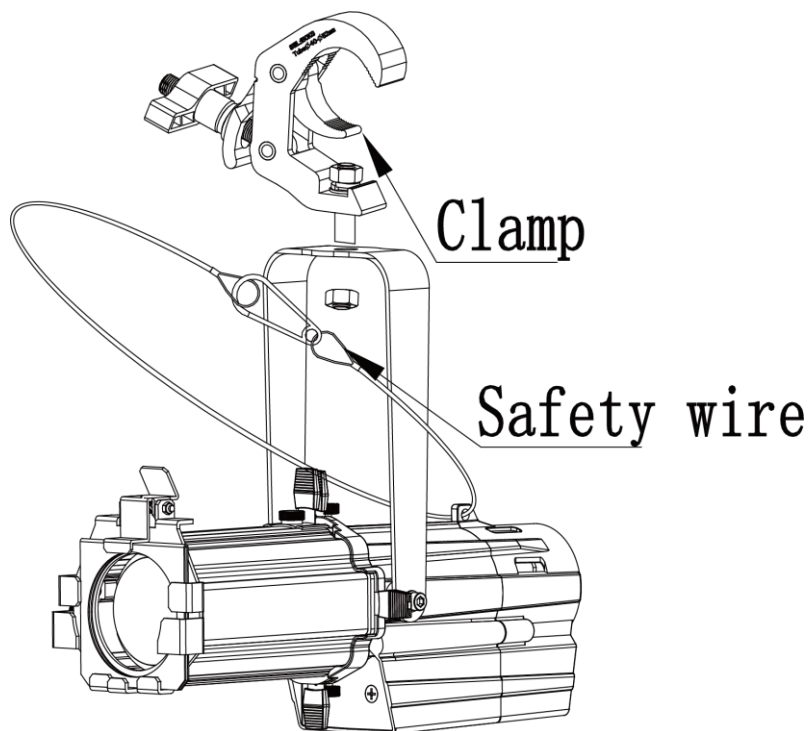

Hanging layout

2.2 POWER CONNECTIONS

- ◆ This product has an auto-ranging power supply that can work with an input voltage range of 100–240 VAC, 50/60 Hz.

AC Plug

Connection	Wire (U.S.)	Wire(Europe)	Screw Color
AC Live	Black	Brown	Yellow/Brass
AC Neutral	White	Blue	Silver
AC Ground	Green/Yellow	Green/Yellow	Green

2.3 Data network requirements

- ◆ Connect the DMX512 controller to the units in series. A DMX 512 data link is required in order to control the fixture via DMX. The fixture has 3/5-pin XLR connectors for DMX data input and output.
- ◆ Each unit has N DMX channels so the DMX Addresses should increase by increments of 1, (Nx1)+1, (Nx2)+1, (Nx3)+1...
- ◆ Any DMX address in the range from 001 to 512 may be used.

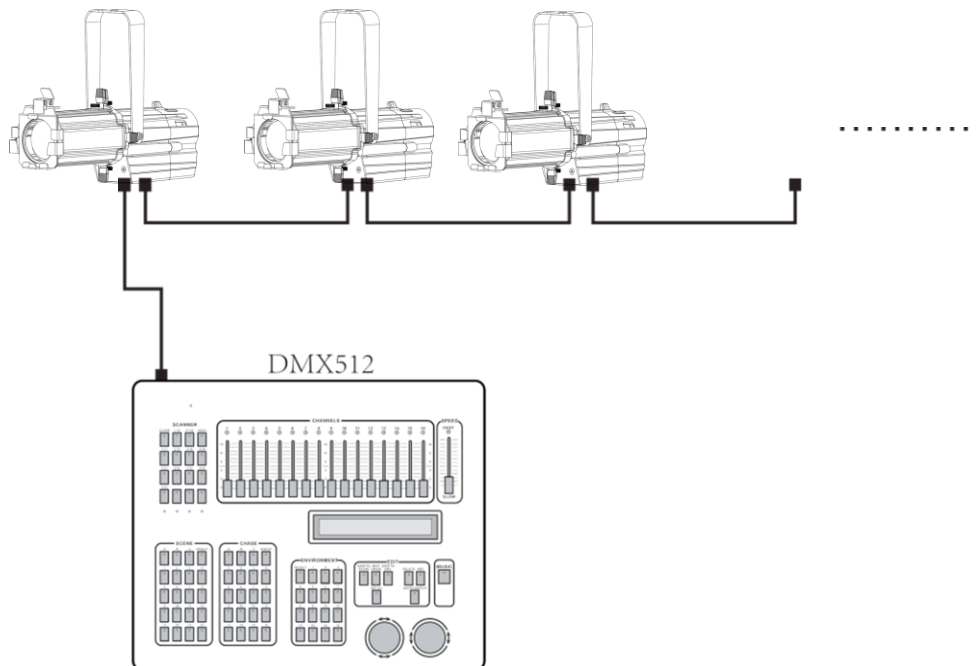

3 FUNCTIONS AND SETTINGS

3.1 DISPLAY OPERATION

- ◆ MENU: Used to access the menu or to return a previous menu option;
- ◆ ENTER: Used to select and store the current menu or confirm the current function value or option within a menu;
- ◆ UP: Navigates downwards through the menu list and increases the numeric value when in a function;
- ◆ DOWN: Navigates upwards through the menu list and decreases the numeric value when in a function;

3.2 Menu Map

STATIC	RED	0-255		Combine [RED][GREEN][BLUE][WHITE]to create an infinite range of colors(0-255). Set the value of the [STROBE](0-25Hz).		
	GREEN	0-255				
	BLUE	0-255				
	WHITE	0-255				
	STROBE	0-25				
ADDRESS	001-512 (default001)			Set the DMX ADDRESS		
RUN MODE	DMX (default)			[DMX] Using the DMX 512 controller to control. [SLAVE] Master--Slave operation.		
	SLAVE					
PERSONALITY	HSIC			Use the menu to select desired channel mode		
	SSP					
	TOUR (default)					
	TR16					
AUTO PROGRAM	AUTO 1	0-255		Programs [CUSTOM 1] to [CUSTOM 2] are fully pre-programmed and can be edited in [EDIT] mode.		
	AUTO 2	0-255				
	...					
	AUTO 10	0-255				
	PR.01					
	PR.02					
EDIT	PROGRAM 01-02	SCENE 01-10	RED	0-255	Enter the [EDIT] mode to edit the custom programs [PROGRAM01] to [PROGRAM2]. Each custom program has 30 scenes that can be edited. Fade transition time, time 0-255 unit is second, fade time setting should be less than time setting. After editing the program, Play in AUTO.	
			GREEN	0-255		
			BLUE	0-255		
			WHITE	0-255		
			STROBE	0-25		
			TIME	0-255		
			FADE	0-255		
	UPLOAD	****	SEND		Select [UPLOAD] to upload the custom programs	
	SETTING	****	RESET	****	RESET	Restore factory settings
			DIMMER	DIM4 (default)		Dimming curves DIM1 (fast) to DIM4 (slow);
OFF						
DMX			SAVE (default)		Hold after loss of DMX signal	
ERROR			BLACK		Blackout after loss of DMX signal	

		DISP KEY	ON (default)	Locks display (passcode is <UP>, <DOWN>,<UP>, <DOWN>, <ENTER>)
			OFF	
		DISP TIME	ON	Display backlight always on
			10s	Turns off display backlight after 10s/30s /2min of inactivity
			30s (default)	
2min				
INFO	FIXTURE HOURS			Hours of fixture use
	VERSION			Software versions
	RDM	UID		Check fixture's ID
		LABEL	ECLIPSE MINI COLOR	Check fixture's LABEL
CCT	1800K			Preset color temperatures
	2200K			
	2700K			
	3000K			
	3200K			
	4000K			
	4500K			
	5000K			
	5600K			
	6000K			
	6500K			
	7000K			
	8000K			
	10000K			
PRESET COLOR	COLOR 1			Preset colour (See Annex I for details)
	COLOR 2			
	...			
	COLOR 24			

All passwords of this product are <UP>, <DOWN>,<UP>, <DOWN>, <ENTER>

4 USING A DMX512 CONTROLLER

4.1 DMX CONTROL

HSIC (7CH)	Value	Function
CH.1	0-255	INTENSIYT
CH.2	0-255	HUE
CH.3	0-255	HUE FINE
CH.4	0-255	SATURATION
CH.5	CCT	
	0-9	NO FUNCTION
	10	1800K
	25	2200K
	40	2700K
	55	3000K
	70	3200K
	85	4000K
	100	4500K
	115	5000K
	130	5600K
	145	6000K
	160	6500K
	175	7000K
	190	8000K
	205	10000K
255	ALL LED	
CH.6	STROBE	
	0-9	NO FUNCTION
	10-99	STROBE FROM SLOD TO FAST (0-25Hz)
	100-109	NO FUNCTION
	110-179	THUNDER STROBE
	180-189	NO FUNCTION
	190-255	RANDOM SROBE
CH.7	CONTROL (EXECUTE AFTER 3 SECONDS)	
	000-010	NO FUNCTION
	011-020	RESERVED
	021-030	RESERVED
	031-040	RESERVED
	041-050	RESERVED
	051-060	RESERVED
	061-070	RESERVED
	071-080	RESERVED
	081-090	RESERVED
	091-100	RESERVED

	101-110	DIMMER OFF
	111-120	DIMMER DIM4
	121-130	RESERVED
	131-140	RESERVED
	141-150	RESERVED
	151-160	RESERVED
	161-170	RESERVED
	171-180	RESERVED
	181-190	RESERVED
	191-200	RESERVED
	201-210	ALL RESET
	211-220	RESERVED
	221-230	RESERVED
	231-240	RESERVED
	241-255	RESERVED

SSP (7CH)	TOUR (11CH)	TR16 (16CH)	Value	Function
CH.1	CH.1	CH.1	0-255	MASTER DIMMER
--	--	CH.2	0-255	MASTER DIMMER FINE
CH.2	CH.2	CH.3	0-255	RED
--	--	CH.4	0-255	RED FINE
CH.3	CH.3	CH.5	0-255	GREEN
--	--	CH.6	0-255	GREEN FINE
CH.4	CH.4	CH.7	0-255	BLUE
--	--	CH.8	0-S255	BLUE FINE
CH.5	CH.5	CH.9	0-255	WHITE
--	--	CH.10	0-255	WHITE FINE
--	CH.6	CH.11	PRESET COLOR	
			0-10	NO FUNCTION
			11-255	PRESET COLOR (See Annex I for details)
--	CH.7	CH.12	CCT	
			0-9	NO FUNCTION
			10	1800K
			25	2200K
			40	2700K
			55	3000K
			70	3200K
			85	4000K
			100	4500K
			115	5000K
			130	5600K
			145	6000K
160	6500K			

			175	7000K
			190	8000K
			205	10000K
			255	ALL LED
CH.6	CH.8	CH.13	STROBE	
			0-9	NO FUNCTION
			10-99	STROBE FROM SLOD TO FAST (0-25Hz)
			100-109	NO FUNCTION
			110-179	THUNDER STROBE
			180-189	NO FUNCTION
			190-255	RANDOM SROBE
--	CH.9	CH.14	Built in effects	
			0-40	NO FUNCTION
			41-50	ATUO1
			51-60	ATUO2
			61-70	ATUO3
			71-80	ATUO4
			81-90	ATUO5
			91-100	ATUO6
			101-110	ATUO7
			111-120	ATUO8
			121-130	ATUO9
			131-140	ATUO10
			141-150	PROGRAM1
			151-160	PROGRAM2
			161-255	NO FUNCTION
	CH.10	CH.15	0-255	AUTO SPEED ADJUSTMENT
CH.7	CH.11	CH.16	CONTROL (EXECUTE AFTER 3 SECONDS)	
			000-010	NO FUNCTION
			011-020	RESERVED
			021-030	RESERVED
			031-040	RESERVED
			041-050	RESERVED
			051-060	RESERVED
			061-070	RESERVED
			071-080	RESERVED
			081-090	RESERVED
			091-100	RESERVED
			101-110	DIMMER OFF
			111-120	DIMMER DIM4
			121-130	RESERVED
			131-140	RESERVED
141-150	RESERVED			

			151-160	RESERVED
			161-170	RESERVED
			171-180	RESERVED
			181-190	RESERVED
			191-200	RESERVED
			201-210	ALL RESET
			211-220	RESERVED
			221-230	RESERVED
			231-240	RESERVED
			241-255	RESERVED

Annex 1

PRESET COLOR	Value	Color Names	x	y	
	0-15	NO FUNCTION			
COLOR 1	16-20	R40	Light Salmon	0.499	0.321
COLOR 2	21-25	L24	Scarlet	0.561	0.296
COLOR 3	26-30	L164	Flame Red	0.659	0.302
	31-40	NO FUNCTION			
COLOR 4	41-45	L08	Dark Salmon	0.498	0.347
COLOR 5	46-50	L25	Sunset Red	0.566	0.359
	51-55	NO FUNCTION			
COLOR 6	56-60	L237	CID(To Tungsten)	0.43	0.365
COLOR 7	61-65	R321	Soft Golden Amber	0.477	0.406
COLOR 8	66-70	L652	Urban Sodium	0.535	0.399
	71-75	NO FUNCTION			
COLOR 9	76-80	L765	LEE Yellow	0.389	0.412
COLOR 10	81-85	L513	Ice And A Slice	0.38	0.447
	86-105	NO FUNCTION			
COLOR 11	106-110	L90	Dark Yellow Green	0.184	0.641
	111-115	NO FUNCTION			
COLOR 12	116-120	R92	Tuiquoise	0.235	0.36
	121-135	NO FUNCTION			
COLOR 13	136-140	L728	Steel Green	0.256	0.302
COLOR 14	141-145	L117	Steel Blue	0.223	0.278
COLOR 15	146-150	L354	Special Steel Blue	0.173	0.265
	151-155	NO FUNCTION			
COLOR 16	156-160	L501	New Colour Blue	0.246	0.249
COLOR 17	161-165	L174	Dark Steel Blue	0.204	0.205
	166-180	NO FUNCTION			
COLOR 18	181-185	L142	Pale Violet	0.209	0.148
	186-195	NO FUNCTION			
COLOR 19	196-200	L794	Pretty'n Pink	0.335	0.251
COLOR 20	201-205	L328	Follies Pink	0.335	0.18
	206-215	NO FUNCTION			
COLOR 21	216-220	L127	Smokey Pink	0.397	0.265
COLOR 22	221-225	L192	Flesh Pink	0.41	0.237
	226-235	NO FUNCTION			
COLOR 23	236-240	L157	Pink	0.457	0.272
COLOR 24	241-245	R332	Cherry Rose	0.489	0.295
	246-255	NO FUNCTION			