

# Studio Panel 300

USER MANUAL

# 1 PRODUCT

## 1.1 TECHNICAL SPECIFICATIONS

Type	Studio Panel 300
LED colors	R*260pcs,G*130pcs,B*130pcs,A*130pcs,L*130pcs,C*130pcs
Angle	Beam Angle:62 ° Field Angle:100°
Power	300W
Control Protocol	DMX512, RDM, W-DMX (Optional)、NFC、Bluetooth
Voltage Range	AC100~240V,50/60Hz
Input Current	110V/3A,220V/1.5A
Protection	IP65
Operation Temperature	-20°C~45°C
Dimensions	574x178x450mm
Weight	11.5kg

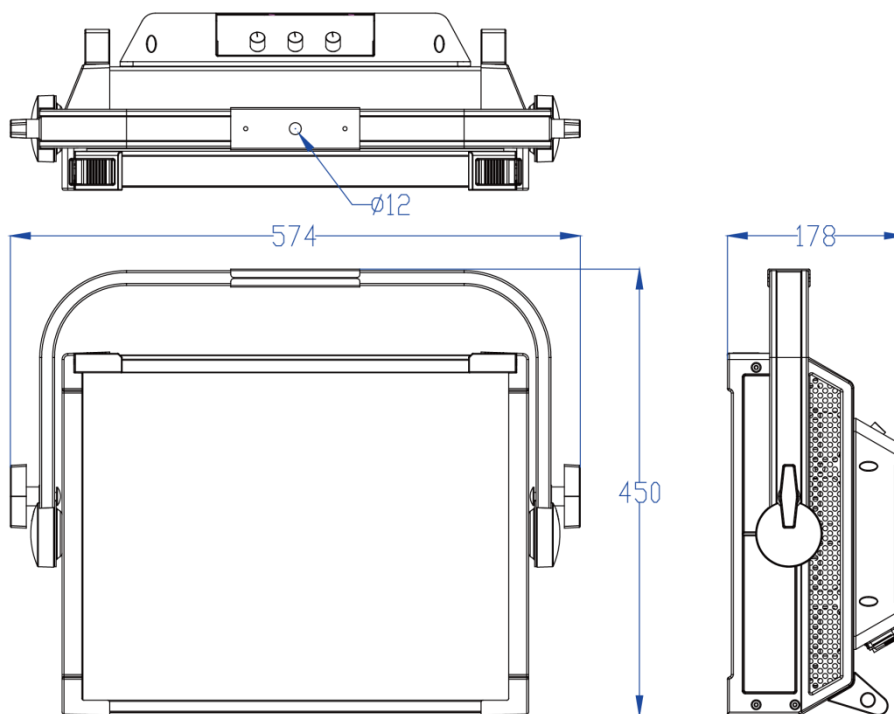

## 1.2 Safety Notes

### IMPORTANT

- This product must be installed by a qualified professional.
- In order to maintain this condition and to ensure a safe operation, it is absolutely necessary for the user to follow the safety instructions and warning notes
- The manufacturer will not accept liability for any resulting damages caused by the non-observance of this manual or any unauthorized modification to the device.

### CAUTION!

- Make sure that the available voltage is not higher than stated on the rear panel.
- Do not touch the power cables if your hands are wet.
- The earth wire must always be connected to the ground. Therefore it is essential to connect the yellow/green conductor to earth.
- Make sure that the power-cord is never crimped or damaged by sharp edges. Check the device and the power-cord from time to time. The electric connection, repairs and servicing must be carried out by a qualified employee.
- Always disconnect power input cable to completely remove power from unit when not in use or before cleaning or servicing the fixture.
- Do not switch the fixture on and off in short intervals as this would reduce the lamp's life.
- Do not touch the device's housing bare hands during its operation (housing becomes hot)! The surface of the product's casing can reach up to 70° C (158° F) during operation. Avoid contact by persons and materials. Do not install the product in a location where there is a risk of accidental contact. Allow the product to cool for at least 10 minutes before handling.
- For replacement use lamps and fuses of same type and rating only.
- Please protect the fixture and avoid destroy during transport and installation. If there is any damage to the coating, the shell may be corroded.
- When hanging lamps and lanterns, it is necessary to verify that facilities and hooks can bear at least 10 times the weight of lamps and lanterns.
- Fix the safety rope at the correct holes only. Only operate the fixture after having checked that the housing is firmly closed and all screws are tightly fastened.
- The maximum ambient temperature 45°C must never be exceeded. Do not operate the product if the ambient temperature (Ta) exceeds 45° C (115° F).
- During the initial start-up some smoke or smell may arise. This is a normal process and does not necessarily mean that the device is defective.

### Electrical Warning

- The light source contained in this luminaire shall only be replaced by the manufacturer or his service agent or a similar qualified person
- For replacement use lamps and fuses of same type and rating only.
- The lens has to be replaced when it is obviously damaged, so that its function is impaired, e. g. due to cracks or deep scratches!

### **Keep the product well away from flammable materials**

- Keep all combustible materials (e.g. fabric, wood, paper) at least 500 mm (20 in) away from the product.
- Ensure that there is free and unobstructed airflow around the product. Provide a minimum

clearance of 150 mm (6 in) around fans and air vents.

- Do not illuminate surfaces within 500mm (20 in) of the product.
- Do not install a fuse that has a higher rating than the one originally installed in the product. Do not bypass fuses.
- Do not stick filters, masks or other materials onto optical components.
- If the fixture seems to be abnormally hot, shows signs of melting or emits smoke, disconnect the fixture from power immediately and allow it to cool. Do not touch the fixture without heatproof safety gloves. Keep the fixture well away from combustible and flammable materials.

**Do not point the front of the fixture towards the sun or other strong light sources. The front lens focuses and concentrates light just like a magnifying glass. Strong light can cause internal damage to the fixture, melting components or starting an internal fire within seconds.**

**To avoid problems from strong light sources:**

- Do not expose the front of a fixture to sunlight or any other strong light source. Avoid pointing other high-powered beam lights directly at the fixture.
- Do not focus a light beam from one lighting fixture directly towards another.
- For outdoor applications during daylight, make sure that the front face of any fixture is shielded or points away from the sun, even when not in use.
- Do not expose the product to heat (from other lighting fixtures for example).

## 2 INSTALLATION

### 2.1 MOUNTING

#### Truss installation

- ◆ Keep all combustible materials (e.g. fabric, wood, paper) at least 500 mm (20 in.) away from the product.
- ◆ For overhead use, always install a safety cable that can hold at least 10 times the weight of the fixture.
- ◆ For overhead installation, the fixture must be always secured with a safety wire that can bear at least 10 times the weight of the fixture;
- ◆ Secure the fixture with a safety cable through the rear safety eye and truss as shown..
- ◆ Ensure that the structure (truss) to which you are attaching the fixture is secure

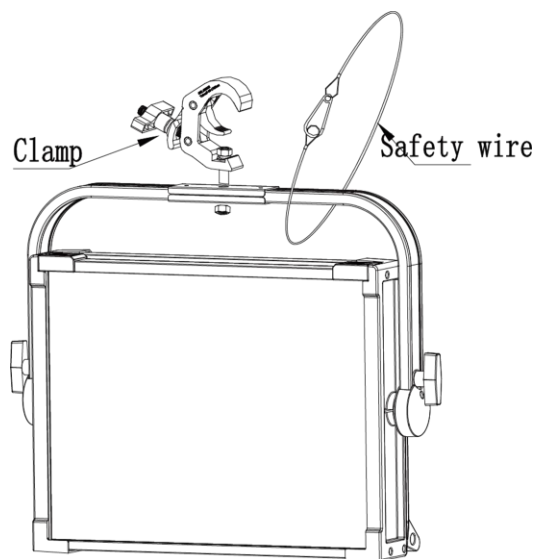

### 2.2 Fuse replacement

- ◆ Remove the safety cap by a screwdriver.
- ◆ Fetch the old fuse from safety cap.
- ◆ Install a new fuse.
- ◆ Install the safety cap.

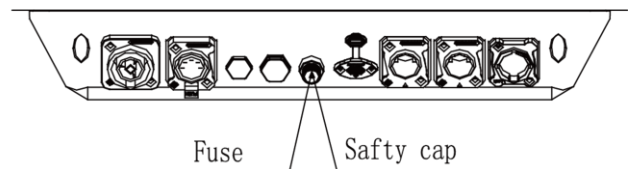

## 2.3 POWER CONNECTIONS

- ◆ POWER Linking: 3 units@110V; 6 units@220V.
- ◆ This product has an auto-ranging power supply that can work with an input voltage range of 100–240 VAC, 50/60 Hz.

AC Plug

Connection	Wire (U.S.)	Wire(Europe)	Screw Color
AC Live	Black	Brown	Yellow/Brass
AC Neutral	White	Blue	Silver
AC Ground	Green/Yellow	Green/Yellow	Green

## 2.4 Data network requirements

- ◆ Connect the DMX512 controller to the units in series. A DMX 512 data link is required in order to control the fixture via DMX. The fixture has 3/5-pin XLR connectors for DMX data input and output.
- ◆ Each unit has N DMX channels so the DMX Addresses should increase by increments of 1, (Nx1)+1, (Nx2)+1, (Nx3)+1...
- ◆ Any DMX address in the range from 001 to 512 may be used.
- ◆ Connect the DMX-output of the first fixture in the DMX chain with the DMX-input of the next fixture. Always connect one output with the input of the next fixture until all fixtures are connected.
- ◆ Caution: At the last fixture, the DMX-cable has to be terminated with a terminator. Solder a 120 Ω resistor between Signal (-) and Signal (+) into a 3/5-pin XLR-plug and plug it in the DMX-output of the last fixture.

DMX-output  
XLR mounting-sockets

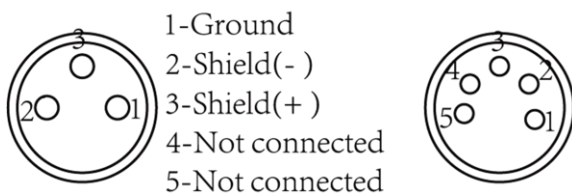

DMX-input  
XLR mounting-plugs

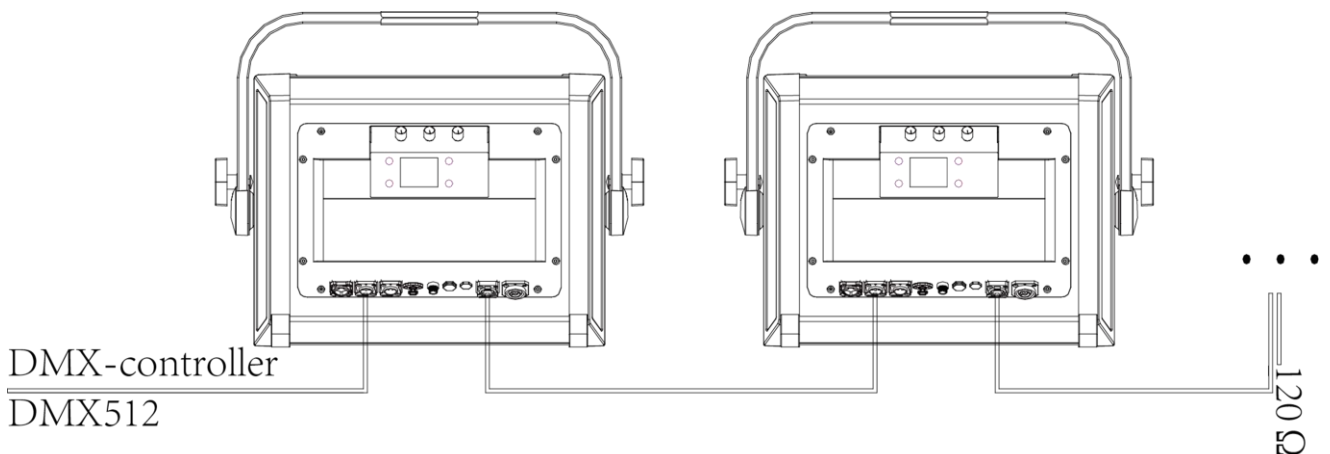
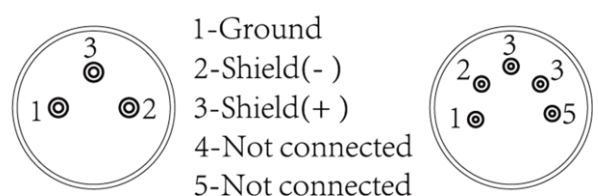

# 3 FUNCTIONS AND SETTINGS

## 3.1 DISPLAY OPERATION

- ◆ MENU: Used to access the menu or to return a previous menu option;
- ◆ ENTER: Used to select and store the current menu or confirm the current function value or option within a menu;
- ◆ UP: Navigates downwards through the menu list and increases the numeric value when in a function;
- ◆ DOWN: Navigates upwards through the menu list and decreases the numeric value when in a function;

## 3.2 Menu Map

<b>KNOB MODE</b>	1.DIMMER 0-100%	2.CCT 1800-10000K	3.GREEN ±25	In this menu you can set and adjust the desired manual mode
	1.H 0-100%	2.S 0-100%	3.I 0-100%	
<b>STATIC</b>	MANUAL	RED	0-255	Combine [RED][GREEN][BLUE][LIME][AMBER][CYAN] to create an infinite range of colors(0-255). Set the value of the [STROBE](0-25Hz).
		GREEN	0-255	
		BLUE	0-255	
		AMBER	0-255	
		LIME	0-255	
		CYAN	0-255	
		STROBE	0-25	
	CCT	1800K		Preset color temperatures
		2200K		
		2700K		
		3000K		
		3200K		
		4000K		
		4500K		
		5000K		
		5600K		
		6000K		
6500K				
PRESET COLOR	COLOR 1		Preset color (See Annex I for details)	
	COLOR 2			
	...			
	COLOR 48			
CMY	CYAN		Cyan、Magenta、Yellow color	
	MAGENTA			
	YELLOW			
<b>ADDRESS</b>	001 – 512 (default001)			Set the DMX ADDRESS
<b>RUN MODE</b>	DMX512 (default)			[DMX] Using the DMX 512 controller to

	SLAVE				control;[SLAVE] Master--Slave operation.
<b>PERSONALITY</b>	BASIC				Use the menu to select desired channel mode
	SSP				
	TOUR (default)				
	TR16				
	HSIC				
	CMY				
<b>AUTO PROGRAM</b>	AUTO 1				Selects automatic AUTO program and AUTO program speed. Programs [CUSTOM 1] to [CUSTOM 2] are fully pre-programmed and can be edited in [EDIT] mode.
	AUTO 2				
	...				
	AUTO 10				
	PR 01				
	PR 02				
<b>EDIT</b>	PROGRAM 1-2	SCENE 1-10	RED	0-255	Enter the [EDIT] mode to edit the custom programs [PROGRAM01] to [PROGRAM2]. Each custom program has 30 scenes that can be edited. Fade transition time, time 0-255 unit is second, fade time setting should be less than time setting. After editing the program, Play in AUTO.
			GREEN	0-255	
			BLUE	0-255	
			AMBER	0-255	
			LIME	0-255	
			CYAN	0-255	
			STROBE	0-25	
			CCT	0-255	
			COLOR	0-255	
			TIME	0-255	
	FADE	0-255			
	CLEAR	PROGRAM 1-2			
	UPLOAD	****	SEND	OK	upload the custom programs
<b>SETTING</b> (****)	RESET	RESET	****	OK	Restore factory settings
		WDMX HIDE	YES	NO	Hide wireless mode WDMX reset and signal hide and the default is wired mode only
	DIMMER	DMI4 (default)			Dimming curves <b>DIM1</b> (fast) to <b>DIM4</b> (slow);
		OFF			
	DMX ERROR	SAVE (default)			Hold after loss of DMX signal
		BLACK			Blackout after loss of DMX signal
	PWM RATE	1200Hz (default)			Sets the PWM frequency
		2400Hz			
		4000Hz			
		6000Hz			
		25000Hz			
	PERFORM	LIVE (default)			Fan mode low speed
		POWER			Fast rotation of fan, all power
STUDIO			Automatic rotation of fan		
DISP KEY	ON			Locks display (passcode is <UP>, <DOWN>,<UP>, <DOWN>, <ENTER>)	
	OFF (default)				
DISP TIME	ON			Display backlight always on	
	10s			Turns off display backlight after 10s/30s /2min of inactivity	
	30s (default)				

		2min		
WDMX RESET	NO (default)		Do not clear the receiver's message.	
	YES		Clear the receiver's message	
SIGNAL	XLRDMX (default)		ONLY XLR is wire only	
	WDMX		ONLY WDMX is wireless only	
	WDMX TO XLR		WDMX TO DMX is wireless to wired	
LANGUAGE	****	中文	Language settings	
		ENGLISH (default)		
Color Cali	OFF (default)		Full power mode	
	User Calibration	RED	0-255	Manual calibration mode
		GREEN	0-255	
		BLUE	0-255	
		AMBER	0-255	
		LIME	0-255	
		CYAN	0-255	
Factory Calibration		Factory calibration mode		
WIRELESS	WIFI	WIFI MODE	STATION	WiFi settings
			AP	
			SMART	
		SSID	YJSS5552	
		PASSWORD	yj000001	
		LOCAL IP	xxx.xxx.xxx.xxx	
		REMOTE IP	xxx.xxx.xxx.xxx	
		MAC	xx.xx.xx.xx.xx.xx	
		WIFI RESTART	NO	
	YES			
WIFIDEFAULT	NO			
	YES			
BLUETOOTH	MAC	xx.xx.xx.xx.xx.xx	Bluetooth Settings	
	NAME	YJSS5552		
INFO	FIXTURE HOURS		Hours of fixture use	
	TEMPERATURE		LED temperature	
	VERSION		Software versions	
	RDM	UID	0x388Axxxxxxxx	Check fixture's ID
LABEL			Check fixture's LABEL	
UPGRADE FIRMWARE			USB flash disk update software	
All passwords of this product are <UP>, <DOWN>, <UP>, <DOWN>, <ENTER>				

# 4 USING A DMX512 CONTROLLER

## 4.1 DMX CONTROL

HSIC(8CH)	Value	Function
CH.1	0-255	INTENSIYT
CH.2	0-255	HUE
CH.3	0-255	HUE FINE
CH.4	0-255	SATURATION
CH.5	<b>CCT</b>	
	0-9	NO FUNCTION
	10	1800K
	25	2200K
	40	2700K
	55	3000K
	70	3200K
	85	4000K
	100	4500K
	115	5000K
	130	5600K
	145	6000K
	160	6500K
	175	7000K
	190	8000K
205	10000K	
255	10000K	
CH.6	<b>Green Shift</b>	
	0-10	NO FUNCTION
	11-29	FULL MINUS GREEN
	30-69	—99% → -1%
	70-129	NO FUNCTION
	130-189	1% → 99%
	190-255	FULL PLUS GREEN
CH.7	<b>STROBE</b>	
	0-9	NO FUNCTION
	10-99	STROBE FROM (SLOD TO FAST, 0-25Hz)
	100-109	NO FUNCTION
	110-179	LIGHTNING STROBE
	180-189	NO FUNCTION
	190-255	RANDOM STROBE
CH.8	<b>CONTROL (EXECUTE AFTER 3 SECONDS)</b>	
	0-10	NO FUNCTION
	11-60	RESERVED
	61-70	LIVE
	71-80	STUDIO
	81-90	POWER
	91-100	RESERVED

	101-110	DIMMER OFF
	111-120	DIMMER DIM4
	121-150	RESERVED
	151-160	1200Hz
	161-170	2400Hz
	171-180	4000Hz
	181-190	6000Hz
	191-200	25000Hz
	201-210	RESET
	211-255	RESERVED

BASIC (3CH)	SSP (8CH)	TOUR (13CH)	TR16 (20CH)	Value	Function
CH.1	CH.1	CH.1	CH.1	0-255	DIMMER
--	--	--	CH.2	0-255	DIMMER FINE
--	CH.2	CH.2	CH.3	0-255	RED
--	--	--	CH.4	0-255	RED FINE
--	CH.3	CH.3	CH.5	0-255	GREEN
--	--	--	CH.6	0-255	GREEN FINE
--	CH.4	CH.4	CH.7	0-255	BLUE
--	--	--	CH.8	0-255	BLUE FINE
--	CH.5	CH.5	CH.9	0-255	AMBER
--	--	--	CH.10	0-255	AMBER FINE
--	CH.6	CH.6	CH.11	0-255	LIME
--	--	--	CH.12	0-255	LIME FINE
--	CH.7	CH.7	CH.13	0-255	CYAN
--	--	--	CH.14	0-255	CYAN FINE
CH.2	--	CH.8	CH.15	<b>PRESET COLOR</b>	
				0-10	NO FUNCTION
				11-255	PRESET COLOR (See Annex I for details)
CH.3	--	CH.9	CH.16	<b>CCT</b>	
				0-9	NO FUNCTION
				10	1800K
				25	2200K
				40	2700K
				55	3000K
				70	3200K
				85	4000K
				100	4500K
				115	5000K
				130	5600K
				145	6000K
				160	6500K
				175	7000K
190	8000K				
205	10000K				

				255	10000K
CH.4	-	CH.10	CH.17	<b>Green Shift</b>	
				0-10	NO FUNCTION
				11-29	FULL MINUS GREEN
				30-69	—99% → -1%
				70-129	NO FUNCTION
				130-189	1% → 99%
				190-255	FULL PLUS GREEN
-	-	CH.11	CH.18	<b>AUTO</b>	
				0-40	NO FUNCTION
				41-50	AUTO 1
				51-60	AUTO 2
				61-70	AUTO 3
				71-80	AUTO 4
				81-90	AUTO 5
				91-100	AUTO 6
				101-110	AUTO 7
				111-120	AUTO 8
				121-130	AUTO 9
				131-140	AUTO 10
				141-150	PROGRAM 1
				151-160	PROGRAM 2
161-255	NO FUNCTION				
-	-	CH.12	CH.19	0-255	AUTO SPEED ADJUSTMENT
	CH.8	CH.13	CH.20	<b>STROBE</b>	
				0-9	NO FUNCTION
				10-99	STROBE FROM SLOD TO FAST (0-25Hz)
				100-109	NO FUNCTION
				110-179	THUNDER STROBE
				180-189	NO FUNCTION
				190-255	RANDOM SROBE
	CH.9	CH.14	CH.21	<b>CONTROL (EXECUTE AFTER 3 SECONDS)</b>	
				0-10	NO FUNCTION
				11-60	RESERVED
				61-70	LIVE
				71-80	STUDIO
				81-90	POWER
				91-100	RESERVED
				101-110	DIMMER OFF
				111-120	DIMMER DIM4
				121-150	RESERVED
				151-160	1200Hz
				161-170	2400Hz
				171-180	4000Hz
				181-190	6000Hz
191-200	25000Hz				

			201-210	RESET
			211-255	RESERVED

CMY(11CH)	Value	Function
CH.1	0-255	DIMMER
CH.2	0-255	CYAN
CH.3	0-255	MAGENT
CH.4	0-255	YELLOW
CH.5	<b>PRESET COLOR</b>	
	0-10	NO FUNCTION
	11-255	PRESET COLOR (See Annex I for details)
CH.6	<b>CCT</b>	
	0-9	无效
	10	1800K
	25	2200K
	40	2700K
	55	3000K
	70	3200K
	85	4000K
	100	4500K
	115	5000K
	130	5600K
	145	6000K
	160	6500K
	175	7000K
	190	8000K
	205	10000K
255	10000K	
CH.7	<b>Green Shift</b>	
	0-10	NO FUNCTION
	11-29	FULL MINUS GREEN
	30-69	—99% → -1%
	70-129	NO FUNCTION
	130-189	1% → 99%
190-255	FULL PLUS GREEN	
CH.8	<b>AUTO</b>	
	0-40	NO FUNCTION
	41-50	AUTO 1
	51-60	AUTO 2
	61-70	AUTO 3
	71-80	AUTO 4
	81-90	AUTO 5
	91-100	AUTO 6
	101-110	AUTO 7
111-120	AUTO 8	

	121-130	AUTO 9
	131-140	AUTO 10
	141-150	PROGRAM 1
	151-160	PROGRAM 2
	161-255	NO FUNCTION
CH.9	0-255	AUTO SPEED ADJUSTMENT
CH.10	<b>STROBE</b>	
	0-9	NO FUNCTION
	10-99	STROBE FROM SLOD TO FAST (0-25Hz)
	100-109	NO FUNCTION
	110-179	THUNDER STROBE
	180-189	NO FUNCTION
	190-255	RANDOM SROBE
CH.11	<b>CONTROL (EXECUTE AFTER 3 SECONDS)</b>	
	0-10	NO FUNCTION
	11-60	RESERVED
	61-70	LIVE
	71-80	STUDIO
	81-90	POWER
	91-100	RESERVED
	101-110	DIMMER OFF
	111-120	DIMMER DIM4
	121-150	RESERVED
	151-160	1200Hz
	161-170	2400Hz
	171-180	4000Hz
	181-190	6000Hz
	191-200	25000Hz
	201-210	RESET
211-255	RESERVED	

## Annex 1

PRESET COLOR	Value	Color Names		x	y
	0-10	NO FUNCTION			
COLOR 1	11-15	L176	Loving Amber	0.407	0.321
COLOR 2	16-20	R40	Light Salmon	0.499	0.321
COLOR 3	21-25	L24	Scarlet	0.561	0.296
COLOR 4	26-30	L164	Flame Red	0.659	0.302
COLOR 5	31-35	L747	Easy White	0.389	0.344
COLOR 6	36-40	R303	Warm Peach	0.448	0.353
COLOR 7	41-45	L08	Dark Salmon	0.498	0.347
COLOR 8	46-50	L25	Sunset Red	0.566	0.359
COLOR 9	51-55	L04	Medium Bastard Amber	0.37	0.335
COLOR 10	56-60	L237	CID(To Tungsten)	0.43	0.365
COLOR 11	61-65	R321	Soft Golden Amber	0.477	0.406
COLOR 12	66-70	L652	Urban Sodium	0.535	0.399
COLOR 13	71-75	L212	LCT Yellow(Y1)	0.34	0.363
COLOR 14	76-80	L765	LEE Yellow	0.389	0.412
COLOR 15	81-85	L513	Ice And A Slice	0.38	0.447
COLOR 16	86-90	L100	Spring Yellow	0.41	0.502
COLOR 17	91-95	L244	LEE Plus Green	0.324	0.388
COLOR 18	96-100	R4430	CalColor 30 Green	0.318	0.44
COLOR 19	101-105	L122	Fern Green	0.234	0.543
COLOR 20	106-110	L90	Dark Yellow Green	0.184	0.641
COLOR 21	111-115	L243	LEE Fluorescent3600K	0.286	0.37
COLOR 22	116-120	R92	Tuiquoise	0.235	0.36
COLOR 23	121-125	R94	Kelly Green	0.185	0.459
COLOR 24	126-130	L327	Forest Green	0.162	0.496
COLOR 25	131-135	L191	Cosmetic Aqua Blue	0.3	0.318
COLOR 26	136-140	L728	Steel Green	0.256	0.302
COLOR 27	141-145	L117	Steel Blue	0.223	0.278
COLOR 28	146-150	L354	Special Steel Blue	0.173	0.265
COLOR 29	151-155	L53	Paler Lavender	0.284	0.284
COLOR 30	156-160	L501	New Colour Blue	0.246	0.249
COLOR 31	161-165	L174	Dark Steel Blue	0.204	0.205
COLOR 32	166-170	L165	Daylight Blue	0.159	0.158
COLOR 33	171-175	L136	Pale Lavender	0.288	0.254
COLOR 34	176-180	L194	Surprise Pink	0.24	0.183
COLOR 35	181-185	L142	Pale Violet	0.209	0.148
COLOR 36	186-190	L700	Perfect Lavender	0.177	0.07
COLOR 37	191-195	L35	Light Pink	0.335	0.289
COLOR 38	196-200	L794	Pretty'n Pink	0.335	0.251
COLOR 39	201-205	L328	Follies Pink	0.335	0.18
COLOR 40	206-210	L795	Magical Magenta	0.327	0.138
COLOR 41	211-215	L154	Pale Rose	0.35	0.318
COLOR 42	216-220	L127	Smokey Pink	0.397	0.265
COLOR 43	221-225	L192	Flesh Pink	0.41	0.237
COLOR 44	226-230	L332	Special Rose Pink	0.465	0.193
COLOR 45	231-235	L790	Moroccan Pink	0.378	0.324
COLOR 46	236-240	L157	Pink	0.457	0.272
COLOR 47	241-245	R332	Cherry Rose	0.489	0.295
COLOR 48	246-250	L128	Cool LED Bright Pink	0.57	0.263
	251-255	NO FUNCTION			