

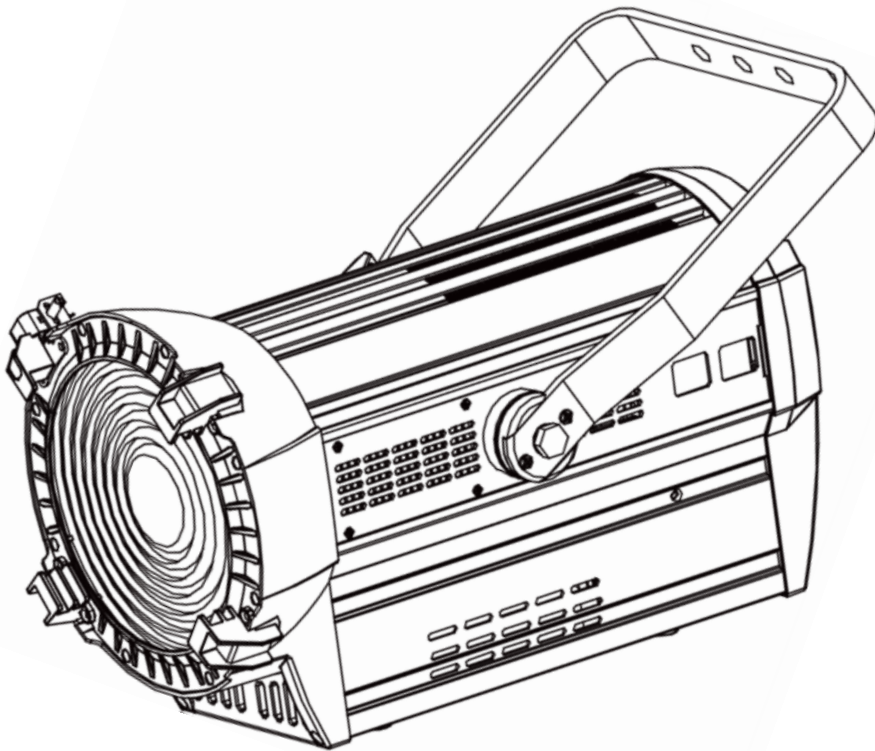

**LEDING**



**XPRESSION**

**250RGBLA**

**USER MANUAL**

# 1 PRODUCT

## 1.1 TECHNICAL SPECIFICATIONS

LED colors	RGBAL 200W LED
Power	240W
Voltage Range	AC100~240V,50/60Hz
Protection	IP20
Operation Temperature	0°C~45°C
Dimensions	510X285X261mm
Weight	7.6kg

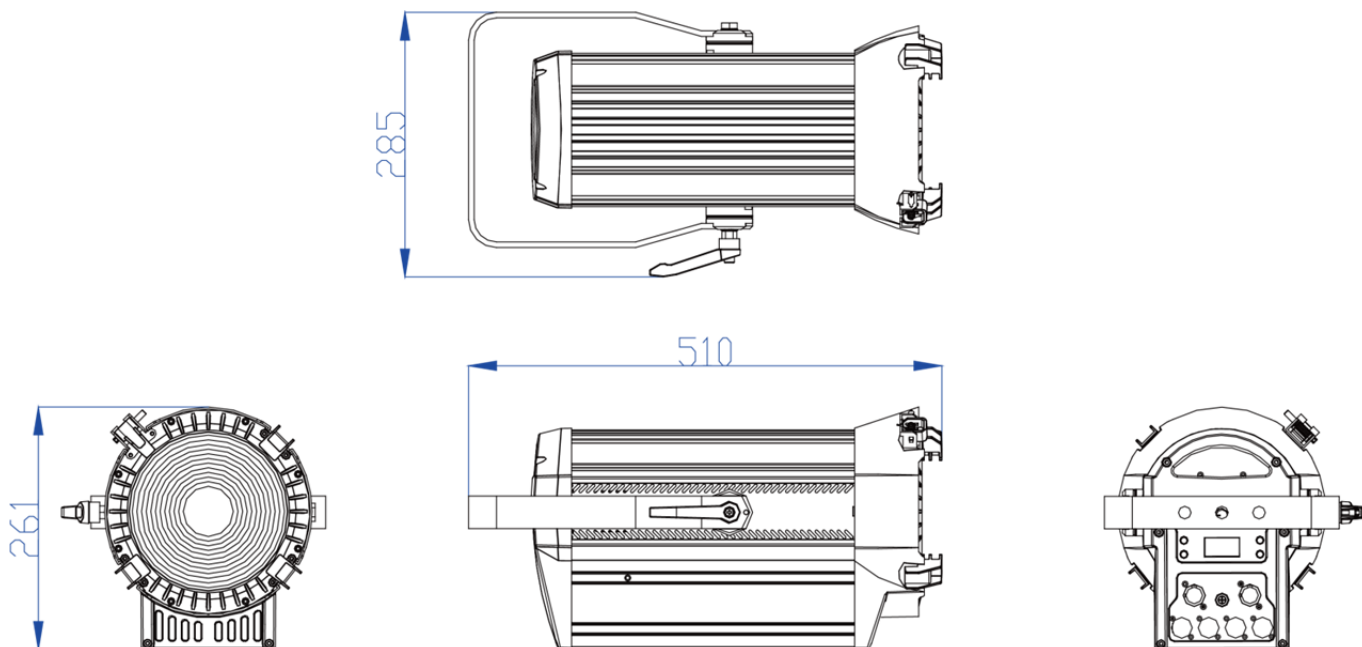

## 1.2 Safety Notes

### **IMPORTANT**

- This product must be installed by a qualified professional.
- In order to maintain this condition and to ensure a safe operation, it is absolutely necessary for the user to follow the safety instructions and warning notes
- The manufacturer will not accept liability for any resulting damages caused by the non-observance of this manual or any unauthorized modification to the device.

### **CAUTION!**

- Make sure that the available voltage is not higher than stated on the rear panel.
- Do not touch the power cables if your hands are wet.
- The earth wire must always be connected to the ground. Therefore it is essential to connect the yellow/green conductor to earth.
- Make sure that the power-cord is never crimped or damaged by sharp edges. Check the device and the power-cord from time to time. The electric connection, repairs and servicing must be carried out by a qualified employee.
- Always disconnect power input cable to completely remove power from unit when not in use or before cleaning or servicing the fixture.
- Do not switch the fixture on and off in short intervals as this would reduce the lamp's life.
- Do not touch the device's housing bare hands during its operation (housing becomes hot)! The surface of the product's casing can reach up to 70° C (158° F) during operation. Avoid contact by persons and materials. Do not install the product in a location where there is a risk of accidental contact. Allow the product to cool for at least 10 minutes before handling.
- For replacement use lamps and fuses of same type and rating only.
- Please protect the fixture and avoid destroy during transport and installation. If there is any damage to the coating, the shell may be corroded.
- When hanging lamps and lanterns, it is necessary to verify that facilities and hooks can bear at least 10 times the weight of lamps and lanterns.
- Fix the safety rope at the correct holes only. Only operate the fixture after having checked that the housing is firmly closed and all screws are tightly fastened.
- The maximum ambient temperature 45°C must never be exceeded. Do not operate the product if the ambient temperature (Ta) exceeds 45° C (115° F).

### **Electrical Warning**

- The light source contained in this luminaire shall only be replaced by the manufacturer or his service agent or a similar qualified person

# 2 INSTALLATION

## 2.1 MOUNTING

### UPRIGHT

- ◆ For overhead use, always install a safety cable that can hold at least 10 times the weight of the fixture.
- ◆ For overhead installation, the fixture must be always secured with a safety wire that can bear at least 10 times the weight of the fixture; Secure the fixture with a safety cable through the rear safety eye as shown.
- ◆ Ensure that the structure (truss) to which you are attaching the fixture is secure

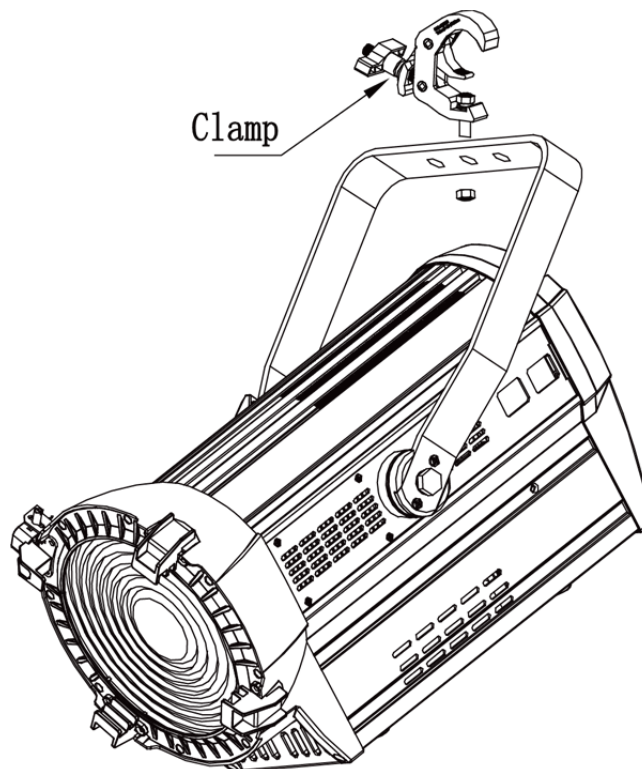

**Hanging layout**

## 2.2 POWER CONNECTIONS

- ◆ POWER Linking: 3 units@110V; 6 units@220V.
- ◆ This product has an auto-ranging power supply that can work with an input voltage range of 100–240 VAC, 50/60 Hz.

### AC Plug

Connection	Wire (U.S.)	Wire(Europe)	Screw Color
AC Live	Black	Brown	Yellow/Brass
AC Neutral	White	Blue	Silver
AC Ground	Green/Yellow	Green/Yellow	Green

## 2.3 Data network requirements

- ◆ Connect the DMX512 controller to the units in series. A DMX 512 data link is required in order to control the fixture via DMX. The fixture has 3/5-pin XLR connectors for DMX data input and output.
- ◆ Each unit has 13 DMX channels so the DMX Addresses should increase by increments of 1, (Nx1)+1, (Nx2)+1, (Nx3)+1...
- ◆ Any DMX address in the range from 001 to 512 may be used.

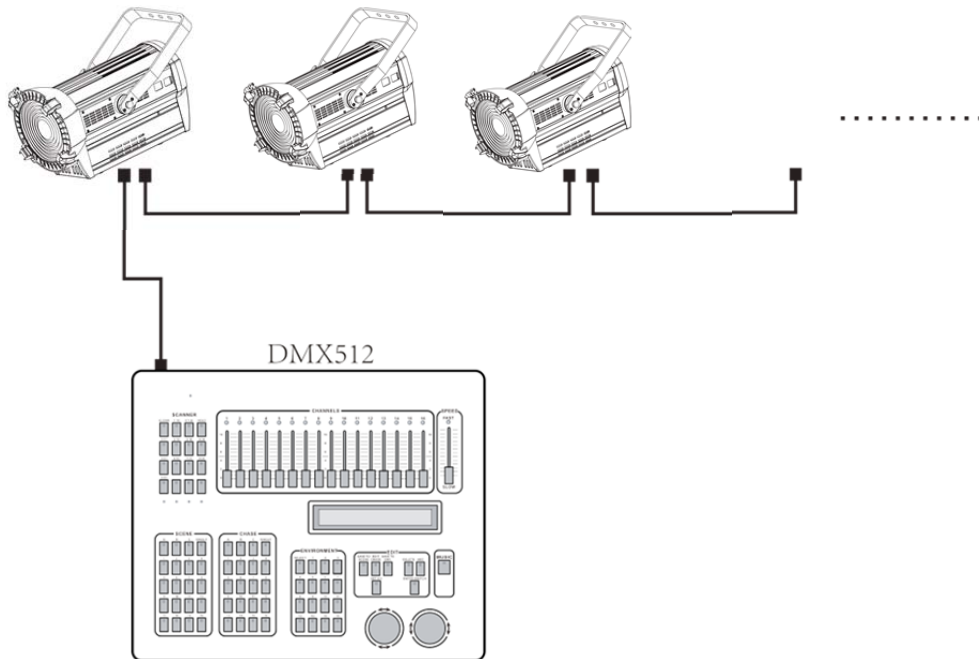

# 3 FUNCTIONS AND SETTINGS

## 3.1 DISPLAY OPERATION

- ◆ MENU: Used to access the menu or to return a previous menu option;
- ◆ ENTER: Used to select and store the current menu or confirm the current function value or option within a menu;
- ◆ UP: Navigates downwards through the menu list and increases the numeric value when in a function;
- ◆ DOWN: Navigates upwards through the menu list and decreases the numeric value when in a function;

## 3.2 Menu Map

KNOB MODE	Mode 1	1.Dimmer、 2.Zoom、 3.CCT		Knob mode select	
	Mode 2	1.Dimmer、 2.Zoom、 3.COLOR			
	Mode 3	1.H、 2.S、 3.I			
	Mode 4	1.Dimmer、 2.CCT、 3.Green			
STATIC	RED	0-255		Combine [RED],[GREEN],[BLUE],[LIME],[AMBER]to create an infinite range of colors(0-255). Set the value of the [STROBE](0-25Hz).	
	GREEN	0-255			
	BLUE	0-255			
	AMBER	0-255			
	LIME	0-255			
	ZOOM	0-255			
	STROBE	0-25			
ADDRESS	001-512 (default001)		Set the DMX ADDRESS		
RUN MODE	DMX (default)		[DMX] Using the DMX 512 controller to control:[SLAVE] Master--Slave operation.		
	SLAVE				
PERSONALITY	HSIC		Use the menu to select desired channel mode		
	SSP				
	TOUR (default)				
	TR16				
AUTO PROGRAM	AUTO 1	0-255		Selects automatic AUTO program and AUTO program speed. Programs [CUSTOM 1] to [CUSTOM 2] are fully pre-programmed and can be edited in [EDIT] mode.	
	AUOT 2	0-255			
	...	0-255			
	AUTO 10	0-255			
	PR 1				
	PR 2				
EDIT	PROGRAM 1-2	SCENE 01-10	RED	0-255	Enter the [EDIT] mode to edit the custom programs [PROGRAM01] to [PROGRAM2]. Each custom program has 30 scenes that can be edited. Fade transition time, time 0-255 unit is second, fade time setting should be less than time setting. After editing the program, Play in AUTO.
			GREEN	0-255	
			BLUE	0-255	
			AMBER	0-255	
			LIME	0-255	
			ZOOM	0-255	
			STROBE	0-25	
			TIME	0-255	

			FADE	0-255	
	UPLOAD	****	SEND		Select <b>[UPLOAD]</b> to upload the custom programs
SETTING	****	RESET	****	RESET	Restore factory settings
		DIMMER	DIM4 (default)		Dimming curves <b>DIM1</b> (fast) to <b>DIM4</b> (slow);
			OFF		
		DMX ERROR	SAVE (default)		Hold after loss of DMX signal
			BLACK		Blackout after loss of DMX signal
		LED PWM	1200HZ (default)		Sets the PWM frequency
			2400HZ		
			4000HZ		
			6000HZ		
			25000HZ		
		PERFORM	LIVE (default)		Fan mode low speed
			POWER		Fast rotation of fan, all power
			STUDIO		Automatic rotation of fan
		DISP KEY	ON (default)		Locks display (passcode is <UP>, <DOWN>, <UP>, <DOWN>, <ENTER>)
			OFF		
DISP TIME	ON		Display backlight always on		
	10s		Turns off display backlight after 10s/30s /2min of inactivity		
	30s (default)				
	2min				
INFO	FIXTURE HOURS			Hours of fixture use	
	VERSION			Software versions	
	RDM	UID	0x388Axxxxxxx	Check fixture's ID	
CCT	1800K			Preset color temperatures	
	2200K				
	2700K				
	3000K				
	3200K				
	4000K				
	4500K				
	5000K				
	5600K				
	6000K				
	6500K				
	7000K				
	8000K				
10000K					
PRESET COLOR	COLOR 1			Preset colour (See Annex I for details)	
	COLOR 2				
	...				
	COLOR 48				

All passwords of this product are <UP>, <DOWN>, <UP>, <DOWN>, <ENTER>

# 4 USING A DMX512 CONTROLLER

## 4.1 DMX CONTROL

HSIC (8CH)	Value	Function
CH.1	0-255	INTENSIYT
CH.2	0-255	HUE
CH.3	0-255	HUE FINE
CH.4	0-255	SATURATION
CH.5	<b>CCT</b>	
	0-9	NO FUNCTION
	10	1800K
	25	2200K
	40	2700K
	55	3000K
	70	3200K
	85	4000K
	100	4500K
	115	5000K
	130	5600K
	145	6000K
	160	6500K
	175	7000K
	190	8000K
	205	10000K
255	10000K	
CH.6	<b>STROBE</b>	
	0-9	NO FUNCTION
	10-99	STROBE FROM SLOD TO FAST (0-25Hz)
	100-109	NO FUNCTION
	110-179	THUNDER STROBE
	180-189	NO FUNCTION
	190-255	RANDOM SROBE
CH.7	0-255	ZOOM
CH.8	<b>CONTROL (EXECUTE AFTER 3 SECONDS)</b>	
	000-010	NO FUNCTION
	011-020	RESERVED
	021-030	RESERVED
	031-040	RESERVED

	041-050	RESERVED
	051-060	RESERVED
	061-070	LIVE
	071-080	STUDIO
	081-090	POWER
	091-100	RESERVED
	101-110	DIMMER OFF
	111-120	DIMMER DIM4
	121-130	RESERVED
	131-140	RESERVED
	141-150	RESERVED
	151-160	1200Hz
	161-170	2400Hz
	171-180	4000Hz
	181-190	6000Hz
	191-200	25000Hz
	201-210	ALL RESET
	211-220	ZOOM RESET
	221-230	RESERVED
	231-240	RESERVED
	241-255	RESERVED

SSP (9CH)	TOUR (13CH)	TR16 (19CH)	Value	Function
CH.1	CH.1	CH.1	0-255	MASTER DIMMER
--	--	CH.2	0-255	MASTER DIMMER FINE
CH.2	CH.2	CH.3	0-255	RED
--	--	CH.4	0-255	RED FINE
CH.3	CH.3	CH.5	0-255	GREEN
--	--	CH.6	0-255	GREEN FINE
CH.4	CH.4	CH.7	0-255	BLUE
--	--	CH.8	0-255	BLUE FINE
CH.5	CH.5	CH.9	0-255	AMBER
--	--	CH.10	0-255	AMBER FINE
CH.6	CH.6	CH.11	0-255	LIME
--	--	CH.12	0-255	LIME FINE
--	CH.7	CH.13	<b>PRESET COLOR</b>	
			0-10	NO FUNCTION
			11-255	PRESET COLOR (See Annex I for details)

--	CH.8	CH.14	<b>CCT</b>	
			0-9	NO FUNCTION
			10	1800K
			25	2200K
			40	2700K
			55	3000K
			70	3200K
			85	4000K
			100	4500K
			115	5000K
			130	5600K
			145	6000K
			160	6500K
			175	7000K
			190	8000K
205	10000K			
255	10000K			
CH.7	CH.9	CH.15	<b>STROBE</b>	
			0-9	NO FUNCTION
			10-99	STROBE FROM SLOD TO FAST (0-25Hz)
			100-109	NO FUNCTION
			110-179	THUNDER STROBE
			180-189	NO FUNCTION
190-255	RANDOM SROBE			
CH.8	CH.10	CH.16	0-255	ZOOM
--	CH.11	CH.17	<b>AUTO</b>	
			0-40	NO FUNCTION
			41-50	AUTO 1
			51-60	AUTO 2
			61-70	AUTO 3
			71-80	AUTO 4
			81-90	AUTO 5
			91-100	AUTO 6
			101-110	AUTO 7
			111-120	AUTO 8
			121-130	AUTO 9
			131-140	AUTO 10
			141-150	PROGRAM 1
151-160	PROGRAM 2			

			161-255	NO FUNCTION
--	CH.12	CH.18	0-255	AUTO SPEED ADJUSTMENT
CH.9	CH.13	CH.19	<b>CONTROL</b> (EXECUTE AFTER 3 SECONDS)	
			000-010	NO FUNCTION
			011-020	RESERVED
			021-030	RESERVED
			031-040	RESERVED
			041-050	RESERVED
			051-060	RESERVED
			061-070	LIVE
			071-080	STUDIO
			081-090	POWER
			091-100	RESERVED
			101-110	DIMMER OFF
			111-120	DIMMER DIM4
			121-130	RESERVED
			131-140	RESERVED
			141-150	RESERVED
			151-160	1200Hz
			161-170	2400Hz
			171-180	4000Hz
			181-190	6000Hz
			191-200	25000Hz
			201-210	ALL RESET
			211-220	ZOOM RESET
221-230	RESERVED			
231-240	RESERVED			
241-255	RESERVED			

# Annex 1

PRESET COLOR	Value	Color Names		x	y
	0-10	NO FUNCTION			
COLOR 1	11-15	L176	Loving Amber	0.407	0.321
COLOR 2	16-20	R40	Light Salmon	0.499	0.321
COLOR 3	21-25	L24	Scarlet	0.561	0.296
COLOR 4	26-30	L164	Flame Red	0.659	0.302
COLOR 5	31-35	L747	Easy White	0.389	0.344
COLOR 6	36-40	R303	Warm Peach	0.448	0.353
COLOR 7	41-45	L08	Dark Salmon	0.498	0.347
COLOR 8	46-50	L25	Sunset Red	0.566	0.359
COLOR 9	51-55	L04	Medium Bastard Amber	0.37	0.335
COLOR 10	56-60	L237	CID(To Tungsten)	0.43	0.365
COLOR 11	61-65	R321	Soft Golden Amber	0.477	0.406
COLOR 12	66-70	L652	Urban Sodium	0.535	0.399
COLOR 13	71-75	L212	LCT Yellow(Y1)	0.34	0.363
COLOR 14	76-80	L765	LEE Yellow	0.389	0.412
COLOR 15	81-85	L513	Ice And A Slice	0.38	0.447
COLOR 16	86-90	L100	Spring Yellow	0.41	0.502
COLOR 17	91-95	L244	LEE Plus Green	0.324	0.388
COLOR 18	96-100	R4430	CalColor 30 Green	0.318	0.44
COLOR 19	101-105	L122	Fern Green	0.234	0.543
COLOR 20	106-110	L90	Dark Yellow Green	0.184	0.641
COLOR 21	111-115	L243	LEE Fluorescent3600K	0.286	0.37
COLOR 22	116-120	R92	Tuiquoise	0.235	0.36
COLOR 23	121-125	R94	Kelly Green	0.185	0.459
COLOR 24	126-130	L327	Forest Green	0.162	0.496
COLOR 25	131-135	L191	Cosmetic Aqua Blue	0.3	0.318
COLOR 26	136-140	L728	Steel Green	0.256	0.302
COLOR 27	141-145	L117	Steel Blue	0.223	0.278
COLOR 28	146-150	L354	Special Steel Blue	0.173	0.265
COLOR 29	151-155	L53	Paler Lavender	0.284	0.284
COLOR 30	156-160	L501	New Colour Blue	0.246	0.249
COLOR 31	161-165	L174	Dark Steel Blue	0.204	0.205
COLOR 32	166-170	L165	Daylight Blue	0.159	0.158
COLOR 33	171-175	L136	Pale Lavender	0.288	0.254
COLOR 34	176-180	L194	Surprise Pink	0.24	0.183
COLOR 35	181-185	L142	Pale Violet	0.209	0.148
COLOR 36	186-190	L700	Perfect Lavender	0.177	0.07
COLOR 37	191-195	L35	Light Pink	0.335	0.289
COLOR 38	196-200	L794	Pretty'n Pink	0.335	0.251
COLOR 39	201-205	L328	Follies Pink	0.335	0.18
COLOR 40	206-210	L795	Magical Magenta	0.327	0.138
COLOR 41	211-215	L154	Pale Rose	0.35	0.318
COLOR 42	216-220	L127	Smokey Pink	0.397	0.265
COLOR 43	221-225	L192	Flesh Pink	0.41	0.237
COLOR 44	226-230	L332	Special Rose Pink	0.465	0.193
COLOR 45	231-235	L790	Moroccan Pink	0.378	0.324
COLOR 46	236-240	L157	Pink	0.457	0.272
COLOR 47	241-245	R332	Cherry Rose	0.489	0.295
COLOR 48	246-250	L128	Cool LED Bright Pink	0.57	0.263
	251-255	NO FUNCTION			