

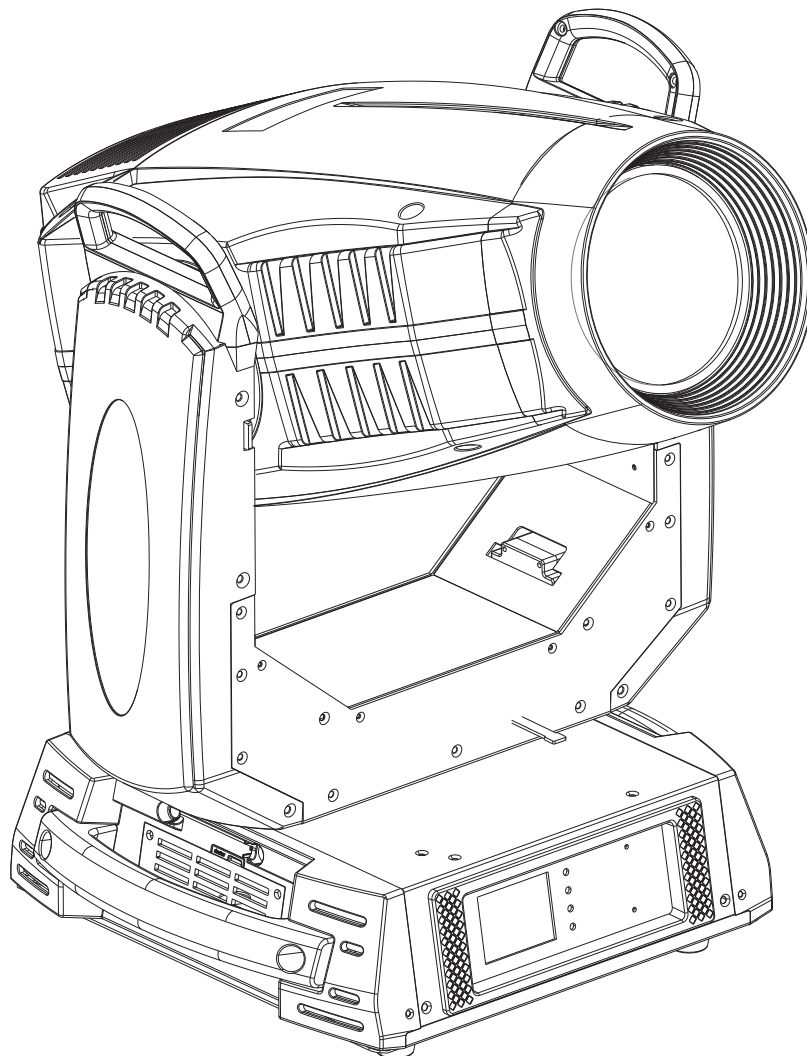

# Razer 440

## USER MANUAL



## Table of content

<b>1.Open–Package guidelines.....</b>	<b>1</b>
<b>1.1 Package.....</b>	<b>1</b>
<b>2.Safety instructions.....</b>	<b>1</b>
<b>3.Operating determination.....</b>	<b>3</b>
<b>4.Rigging the fixture.....</b>	<b>4</b>
<b>4.1 Mounting.....</b>	<b>4</b>
<b>4.2Installing the Clamps.....</b>	<b>4</b>
<b>4.3 Power supply connection and cut off.....</b>	<b>5</b>
<b>4.4 POWER Connection.....</b>	<b>6</b>
<b>4.5 DMX–512 connection/connection between fixtures.....</b>	<b>6</b>
<b>5.Description of the device.....</b>	<b>7</b>
<b>6.Dimension.....</b>	<b>8</b>
<b>7.Display control.....</b>	<b>9</b>
<b>7.1 Navigation in the Menu.....</b>	<b>9</b>
<b>7.2 Display OPeration.....</b>	<b>9</b>
<b>7.3 Menu Maps .....</b>	<b>11</b>
<b>8.DMX protocol.....</b>	<b>12</b>
<b>9.Maintance and cleaning.....</b>	<b>15</b>
<b>10.Electric equipment specification.....</b>	<b>15</b>
<b>10.1 Electrical paramters.....</b>	<b>15</b>
<b>10.2 Weight and dimensions.....</b>	<b>15</b>
<b>10.3 Channel Characteristics.....</b>	<b>15</b>
<b>10.4 Menu Function.....</b>	<b>15</b>
<b>10.5 light table.....</b>	<b>16</b>
<b>10.6 Gobo wheel.....</b>	<b>17</b>
<b>10.7 Color wheel.....</b>	<b>18</b>
<b>11.Electronic drawing.....</b>	<b>19</b>



## 1. Open–Package guidelines

Congratulations on choosing our products! Please carefully read this instruction manual in its entirety and keep it well for using reference. This manual contained about the installation and the relative using information of this products. Please refer to this manual's relative instruction when using this equipment.

This equipment is made of new style, high intensity plastic. It fully shows the modern times light characteristic with beauty structure. And it is made according to CE standard. Fully agree with the international standard of DMX512 agreement.

When receive the product, please be careful to take and put, check if the product has damage or not because of transportation, and check the following parts:

- |                     |                      |
|---------------------|----------------------|
| 1. Signal cable-1PC | 2. Safety cable-1PC  |
| 3. User Manual-1PC  | 4. Omega holder-2PCS |
| 5. Power cable-1PC  | 5. Service card-1PC  |

### 1.1 Package

Unpacking the fixture

1. Open the flight case cover- Fig. 1
2. With one person on each side, lift the fixture out of the flight case.
3. Unlock pan and tilt before operating fixture.

Packing the fixture

1. Disconnect the fixture from power and allow it to cool.
2. Lock arms and head as figure.- Fig.1(PAN Mechanism Lock and Release (every 45°) - Fig.1-1)(Tilt Mechanism Lock and Release (every 45°) - Fig.1-2)
3. Place the fixture in the bottom of the flight case, and cover the case without forcing.

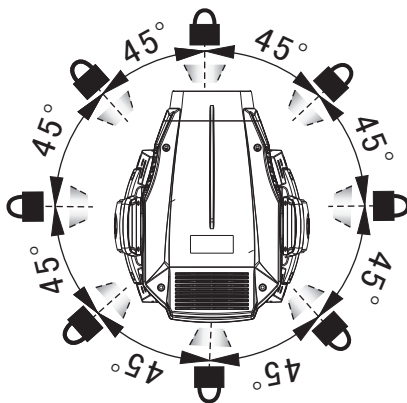

PAN Mechanism Lock Fig.1-1

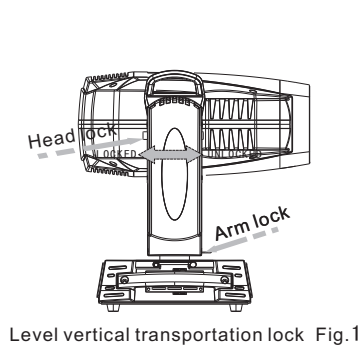

Level vertical transportation lock Fig.1

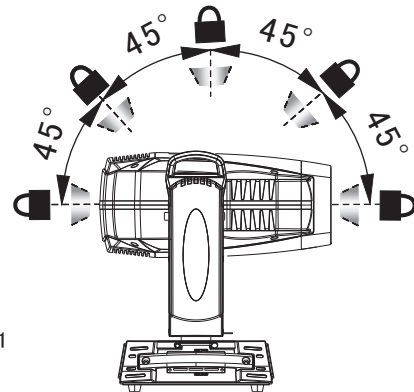

PAN Mechanism Lock Fig.1-2

## 2. Safety instructions

Every person involved with installation and maintenance of this device to:

- Be qualified
- Follow the instructions of this manual.



### CAUTION!

**Be careful with your operations.  
With a high voltage you can suffer  
a dangerous electric shock when touching the wires!**



This device has been shipped with our premises in absolutely perfect condition. In order to maintain this condition and to ensure a safe operation, it is absolutely necessary for the user to follow the safety instructions and warning notes written in this manual.

### Important:





- The manufacturer will not accept liability for any resulting damages caused by the nonobservance of this manual or any unauthorized modification to the device.
- Please consider that damages caused by manual modifications to the device are not subject to warranty.



- Never let the power-cord come into contact with other cables! Handle the power cord and all connections with particular caution!
- Make sure that the available voltage is not higher than stated on the rearpanel.
- Always plug in the power plug least. Make suer that the power-switch is set to off-position before you con ections with themains with particular caution!
- Make sure that the power-cord is never crimped or damaged by sharp edges.Check the decice and the p- ower-cord from time to time.
- Always disconnect from the mains, when the device is not in use or before cleaning it.
- Only handle the power-cord by the plug, Never pull out the plug by tugging the powercord.
- This device falls under protection class I. Therefore it is essential to connect the yellow/green conductor to earth.
- The electric connection, repairs and servicing must be carried out by a qualified employee.
- Do not connect this device to a dimmer pack.
- Do not switch the fixture on and off in short intervals as this would reduce the lamp's life.
- Do not touch the device's housing bare hands during its operation(housing becomes hot)!
- For replacement use lamps and fuses of same type and rating only.

### Eye damage!

**Avoid looking directly into the light source(meant especially for epileptics)!**

- |   |   |
|---|---|
| 750W (2.5m)   | ➤ <b>Minimum distance of illuminated objects</b><br>The projector needs to be positioned so that the objects hit by the beam of light are at least 18 metres from the lens of the projector.  |
| t <sub>a</sub> 40°C   | ➤ <b>Maximum ambient temperature</b><br>Do not operate the fixture if the ambient temperatuer(T <sub>a</sub> ) exceeds 40°C (104°F).  |
| t <sub>c</sub> 80°C   | ➤ <b>Temperature of the external surface</b><br>The maximum temperature that can be reached on the external surface of the fitting, in a thermally steady state, is 80°C (176°F).   |
| IP20  | ➤ <b>IP20 protection rating</b><br>The fitting is protected against penetration by solid of over 12mm (0.47") in diameter (first digit 2), but not against dripping water, rain, splashes or jets of water (second digit 0).  |
|    | ➤ <b>Indoor use only</b>  |
|    | ➤ <b>Not suitable for household illumination</b>  |
| <br><small>Risk Group 1<br/>According to<br/>EN62471</small> | ➤ <b>Photobiological Safety</b><br><b>CAUTION.</b> Do not look directly at the light source. Do not look at the light beam with optical devices or any other tool that could cause light convergence.<br>The fixture must be positioned so that the minimum distance between the front lens and human eye is at least 3metres to prevent personal photobiological risks.                      |
|    | ➤ <b>Mounting surfaces</b><br>It is permissible to mount the fitting on normally flammable surfaces.  |
| CE  | ➤ The products to which this manual refers comply with the European Directives pursuant to:<br>• 2006/95/EC - Safety of electrical equipment supplied at low voltage (LVD)<br>• 2004/108/EC - Electromagnetic Compatibility (EMC)<br>• 2011/65/EU - Restriction of the use of certain hazardous substances (RoHS)<br>• 2009/125/EC - EcoDesign requirements for Energy-related Products (ErP) |
|    | ➤ <b>Protection against electrical shock</b><br>Connection must be made to a power supply system fitted with efficient earthing (Class I appliance according to standard EN 60598-1). It is, moreover, recommended to protect the supply  |



lines of the projectors from indirect contact and/or shorting to earth by using appropriately sized residual current devices.



➤ **Disposing**

This product is supplied in compliance with European Directive 2012/19/EU-Waste Electrical and Electronic Equipment (WEEE). To preserve the environment please dispose/recycle this product at the end of its life according to the local regulation.



➤ **Battery**

This product contains a rechargeable lead-acid or lithium iron tetraphosphate battery. To preserve the environment, please dispose the battery at the end of its life according to the regulation in force.



➤ **Lamp**

The fitting mounts a high-pressure lamp that needs an external igniter. This igniter is fitted onto the apparatus. -Carefully read the "operating instructions" provided by the lamp manufacturer.  
-Immediately replace the lamp if damaged or deformed by heat.



➤ **Maintenance**

Before starting any maintenance work or cleaning the projector, cut off power from the mains supply. After switching off, do not remove any parts of the fitting for at least 10 minutes. After this time the likelihood of the lamp exploding is virtually small. If it is necessary to replace the lamp, wait for another 15 minutes to avoid getting burnt. The fitting is designed to hold in any splinters produced by a lamp exploding.

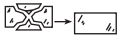

### 3. Operating determinations

- This device is a moving-head for creating decorative effects and was designed for indoor use only.
- If the device has been exposed to drastic temperature fluctuation (e.g. after transportation), do not switch it on immediately. The arising condensation water might damage your device. Leave the device switched off until it has reached room temperature.
- Never run the device without lamp!
- Do not shake the device, avoid brute force when installing or operating the device.
- Never lift the fixture by holding it at the projector head, as the mechanics may be damaged. Always hold the fixture at the transport handles.
- When choosing the installation-spot, please make sure that the device is not exposed to heat, moisture or dust. There should not be any cables lying around. You endanger your own and the safety of others!
- The minimum distance between light output and the illuminated surface must be more than 0.2 meters.
- Make sure that the area below the installation place is blocked when rigging, derigging or servicing the fixture.
- Always fix the fixture with an appropriate safety rope, fix the safety rope at the correct holes only.
- Operate the fixture after having checked that the housing is firmly closed and all screws are tightly fastened.
- The lamp must never be ignited if the objective-lens or any housing-cover is open, as discharge lamps may explode and emit a high ultraviolet radiation, which may cause burns.
- The maximum ambient temperature 40° C must never be exceeded.
- Operate the device only after having familiarized with its functions. Do not permit operation by persons not qualified for operating the device. Most damages are the result of unprofessional operation!
- Please use the original packaging if the device is to be transported.
- Please consider that unauthorized modifications on the device are forbidden due to safety reasons!
- If this device will be operated in any way different to the one described in this manual, the product may suffer damages and the guarantee becomes void. Furthermore, any other operation may lead to dangers like short-circuit, burns, electric shock, burns due to ultraviolet radiation, lamp explosion, crash etc.



## 4. Rigging the fixture

### 4.1 Mounting



***Pay attention to the regulations of CE.***

***Installation by qualified staff to complete.***

- ☞ For the various mounting positions of the FIXTURE (standing on the floor, sideways or hanging different accessories kits are available).
- ☞ Through this a safe and firm installation is assured.
- ☞ You'll find special connectors on the bottom side of the system which are put to use here.

### 4.2 Installing the Clamps

Please consider the respective national norms during the Installation! The installation must only be carried out by an authorized dealer!

The installation of the projector has to be built and constructed in a way that it can hold 10 times the weight for 1 hour without any harming deformation.

The installation must always be secured with a secondary safety attachment, e.g. an appropriate catch net. This secondary safety attachment must be constructed in a way that no part of the installation can fall if the main attachment fails.

When servicing the fixture staying in the area below the installation place, on bridges, under high working places and other endangered areas is forbidden.

The operator has to make sure that safety-relating and machine-technical installations are approved by an expert before taking into operation for the first time and after changes before taking into operation another time.

The operator has to make sure that safety-relating and machine-technical installations are approved by an expert after every four years in the course of an acceptance test.

The operator has to make sure that safety-relating and machine-technical installations are approved by a skilled person once a year.

The projector should be installed outside areas where persons may walk by or be seated.

**Important!** Overhead rigging requires extensive experience CE, including (but not limited to) calculating working load limits, installation material being used, and periodic safety inspection of all installation material and the projector. If you lack these qualifications, do not attempt the installation yourself, but instead use a professional structural rigger. Improper installation can result in bodily injury and or damage to property.

The projector has to be installed out of the reach of people.

If the projector shall be lowered from the ceiling or high joists, professional trussing systems have to be used. The projector must never be fixed swinging freely in the room.

**Caution** Projectors may cause severe injuries when crashing down! If you have doubts concerning the safety of a possible installation, do not install the projector!

Before rigging make sure that the installation area can hold a minimum point load of 10 times the projector's weight.



The projector can be placed directly on the stage floor or rigged in any orientation on a truss without altering its operation characteristics.

For overhead use, always install a safety-rope that can hold at least 10 times the weight of the fixture. You must only use safety-ropes with screw on carabines. Pull the safety-rope through the two apertures on the bottom of the base and over the trussing system etc.

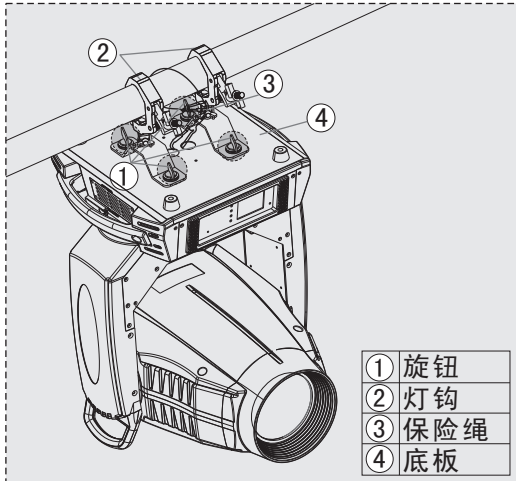

①	Lock catch
②	omega holder
③	secure chain
④	mounting plate



**Warning:** it is necessary to make sure that the installation location is perfectly appropriate, and the installation location is safe and reliable.

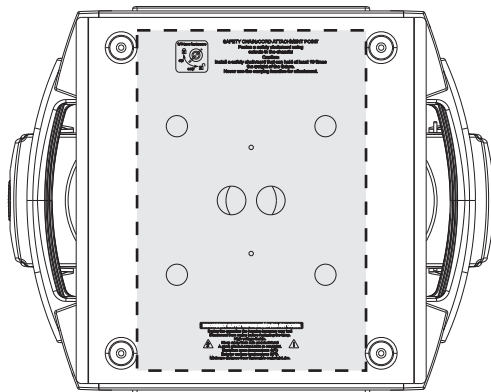

**1/4 turn fasteners**



**SAFETY CHAIN/CORD ATTACHMENT POINT**  
Fasten a safety chain/cord using cutouts in the chassis!  
Caution:  
Install a safety chain/cord that can hold at least 10 times the weight of the fixture.  
Never use the carrying handles for attachment.

**DISCONNECT SUPPLY BEFORE REMOVING ANY COVER**

During the operation the housing becomes very hot  
Disconnect from mains before replacing the lamp.  
High voltage inside.

Keep away from rain and moisture!  
A good ground connection is essential.  
Maximum room temperature: 40°C  
Exterior surface temperature: 80°C  
Minimum distance from flammable material: 0.8m.

### 4.3 Power supply connection and cut off

Connect the light source to the main power source with the plug of the power cord, or cut off the power supply:

Connection: according to procedures, the power plug and socket is inserted into the groove one one alignment, rotation.

Cut off: according to procedures, press the button on the rotating plug, pull out.

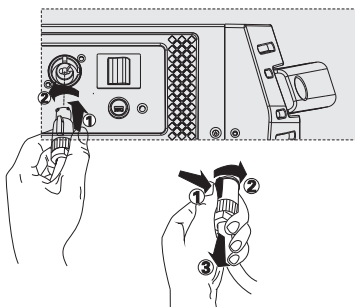



## 4.4 Power Connection

If you wish to change the power supply settings, see the chapter appendix Connect the fixture to the mains with the enclosed power cable and plug.



**Warning:** please verify the power of the power supply equipment prior to the connection! Earth wire must be grounded!

CABLE(EU)	CABLE(US)	Pin	INTERNATIONAL
Brown	Black	Live	<b>L</b>
Light blue	White	Neutral	<b>N</b>
Yellow/Green	Green	Earth	

## 4.5 DMX-512 connection/connection between fixtures

Only use stereo shielded cable and 3-pin XLR-plugs and connectors in order to connect.

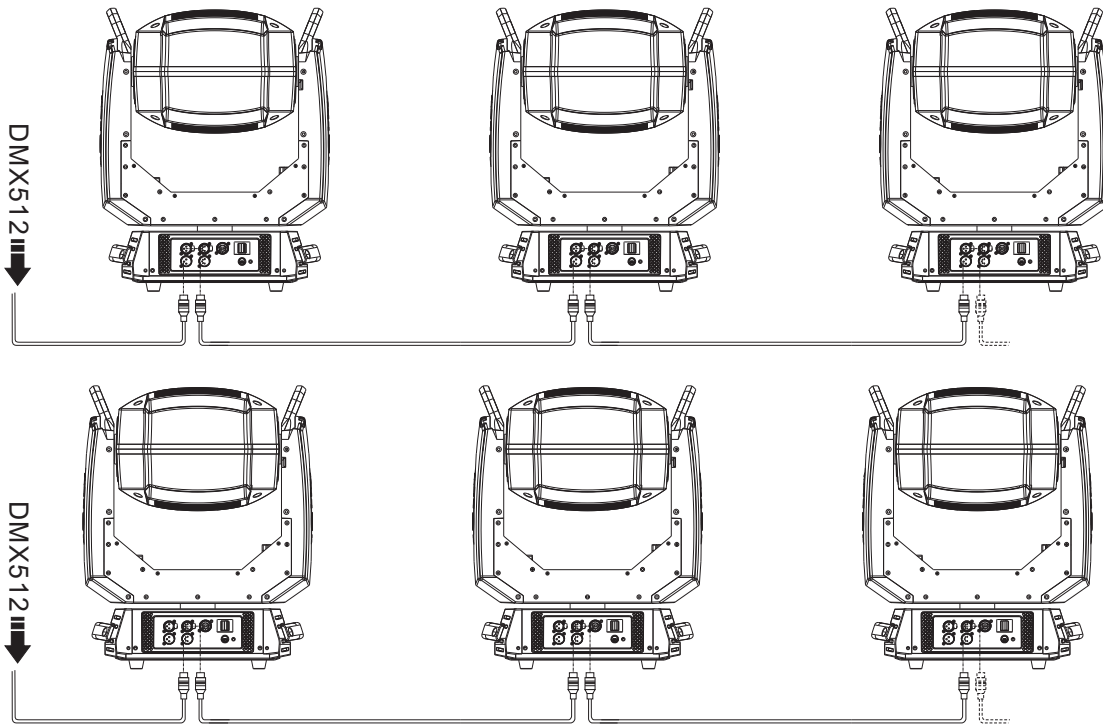

### Caution

At the last fixture, the DMX-cable has to be terminated with a terminator. solder a 120 resistor between signal(-) and Signal (+) into a 3-pin XLR-plug and plug it in the DMX-output of the last fixture.

DMX output 3-pin XLR socket      DMX input 3-pin XLR socket

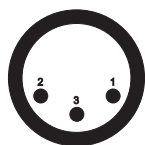
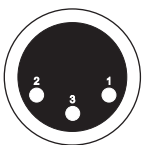

1: Ground  
2: Signal (-)  
3: Signal (+)

DMX output 5-pin XLR socket      DMX input 5-pin XLR socket

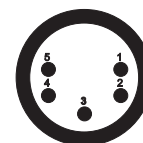
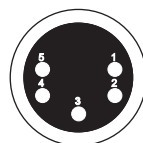

1: Ground  
2: Signal (-)  
3: Signal (+)  
4: N. A.  
5: N. A.



### DMX Terminator Diagram

-For installations where the DMX cable has to run a long distance or is in an electrically noisy environment it is recommended to use a DMX terminator. This helps in preventing corruption of the signal by electrical noise. The DMX terminator is simply an XLR plug with a 120Ω resistor connected between pins 2 and pins 3, which is then plugged into the output XLR socket of the last fixture in the chain.

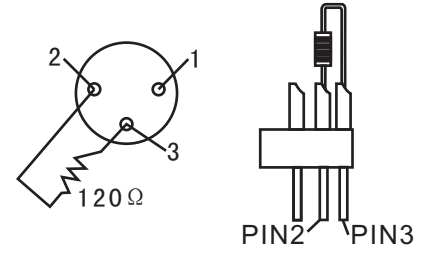

## 5. Description of the device

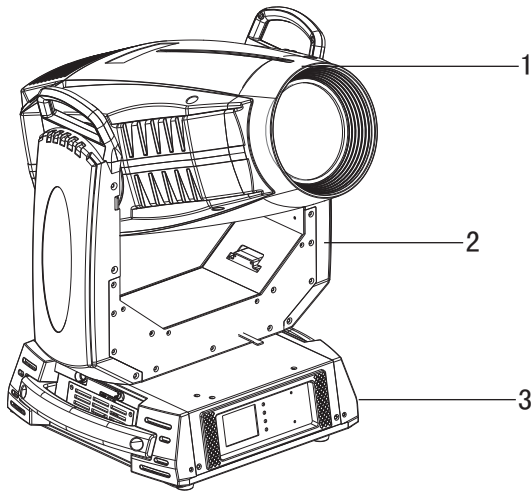

### DESIGN CONSTITUTION

- 1. Head
- 2. Arm
- 3. Base

### CONTROL PANEL

- 4. 3-pin XLR female
- 5. Power-in
- 6. Power switch
- 7. 5-pin XLR female
- 8. Insurance seat
- 9. 3-pin XLR male
- 10. 5-pin XLR male

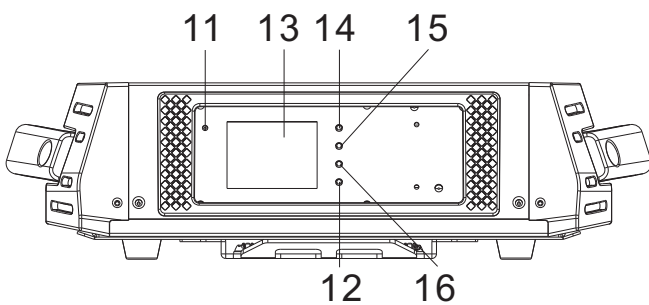
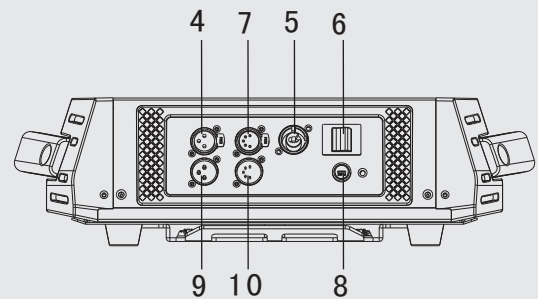

### BACK PANEL

- 11. Status indicator lamp
- 12. ENTER button
- 13. Touch screen (LCD display)
- 14. MODE button
- 15. UP button
- 16. DOWN button



17

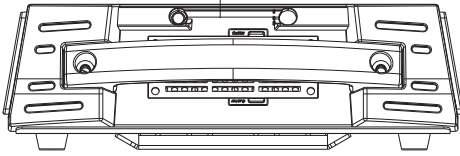

17.WDMX wire

### 6.Dimension

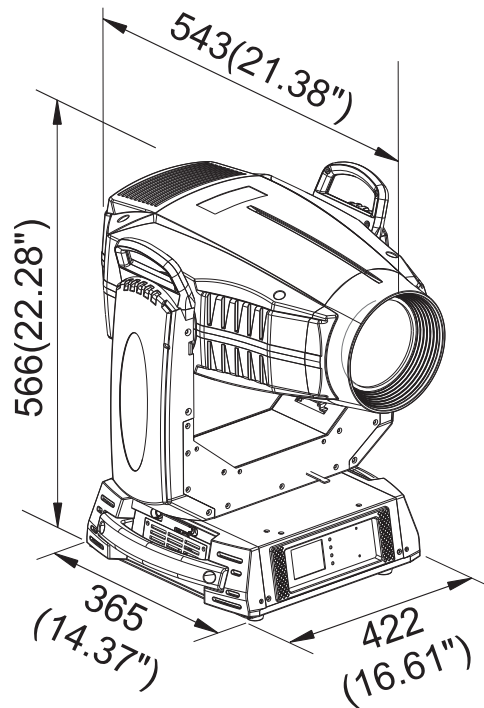
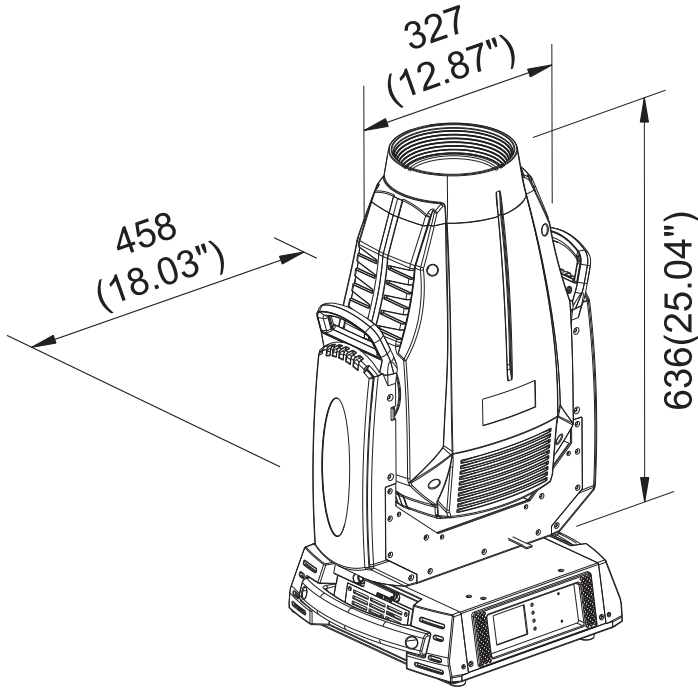



## 7. Display control

### 7.1 Navigation in the Menu

Using the buttons or touch screen, and this can be simply and easily set the address code and functions code.

If you view or modify the lighting feature set, then press ENTER button, the display will enter the menu interface. Both there is sub menu corresponding to the functional operation of the main menu. Each of the menus is representative of the specific features of the lamp. The specific contents shows as the table menu below.

Set or browse lighting function, press UP or DOWN button.

Press ENTER to save your changes or enter the submenu. Press the UP or DOWN can change the numerical (increase or decrease in value).

Press the MODE button to return to menu. Set a time 1 to 10 minutes automatically exit menu interface and close the screen.

### 7.2 Display Operation

Put through power supply, open the power switch of lamps and lanterns, display show the company LOGO website. According to the main interface, as shown in figure:

In the main interface, press "MODE" button to view the software version, press the "UP" "DOWN" can modify the DMX address.

If the screen "🔌" icon is green, said DMX signal connection is normal, this state can be used to check the lamps and lanterns and connection between the control table is normal.

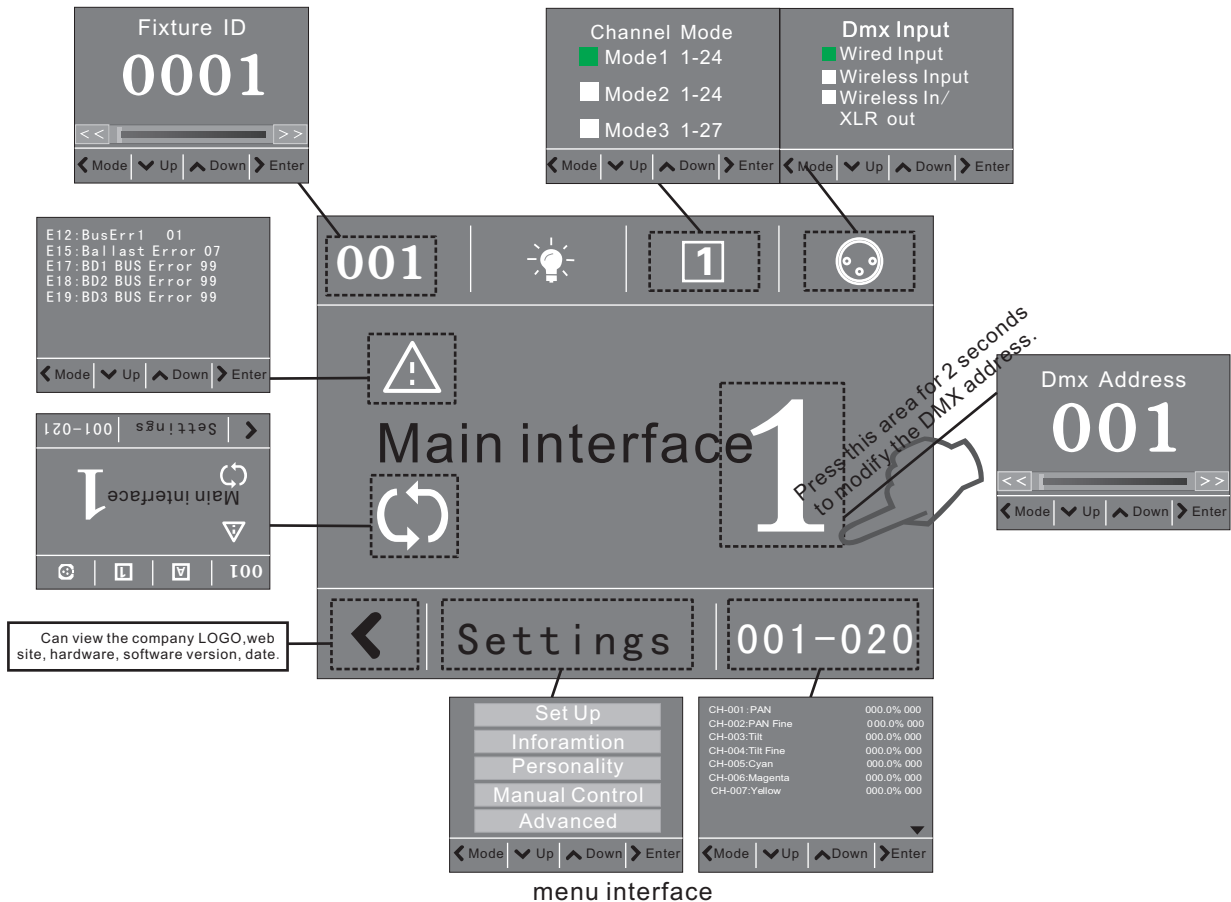

This lamp can be set to turn off the automatic flip screen function, touch this "🔄" icon can be manually flip screen.



\*Click on the main menu of the icon and value to view set of the relevant lighting information. If there is symbol of the "△" on the display, it indicates that the device may be wrong, if the symbol was blue, the contents are errors appeared, click to clear. When the symbol is yellow, you can click on the view and according to the references information to modify, If there is any doubt, please consult the relevant technical personnel. (-for details see attached table).

CODE	ERRO INFO	CHECK MEASURMENT	NOTE
E001	SpiFlashError	Check the welding of memory IC	RESET ERROR
E002	Program Err 1	Check the welding of Chip	
E003	Program Err 2	Check the welding of master IC EP3C	
E005	BD1Init Error	Check the communication signal 485& 485 chip & memory IC	
E006	BD2Init Error		
E007	BD3Init Error		
E012	BusErr	Check main cable ABAB ( 485 ) chip	
E014	SPDError	Check the welding of master IC	
E017	BD1 BUS Error	Check the communication signal& welding of communication chip	
E018	BD2 BUS Error		
E019	BD3 BUS Error		
E021	Pan FB. Err	Check the light coupling line, optical coupling switch and a plate of the relative position measurement	
E023	Tilt FB. Err		
E022	Pan Zero Err	Check cable of sensor, distance and location of ,magnets and sensor	
E024	Tilt Zero Err		
E025	Prism Err1		
E026	Prism Err2		
E027	R.Gobo Err1		
E028	R.Gobo Err2		
E029	A.Gobo Err		
E031	Zoom Err		
E032	Focus Err		
E033	St. Gobo Err		
E034	ColourW. Err		
E035	Iris Err		
E036	Cyan Err		
E037	Magenta Err		
E038	Yellow Err		
E039	CTO Err		
E040	Frost Err		
E042	B.Fan1 Error	Check the fan of head	
E044	B.Fan2 Error		
E053	L.Fan1 Error	Check if the fan(80) of the lamp holder is working	
E055	L.Fan2 Error		



### 7.3 Unit Menu

			Remark
Set up	Dmx Address	001~XXX	Dmx Address
	Channel Mode	Mode1 1~24	default Mode1
		Mode2 1~24	
Mode3 1~27			
	Fixture Id	0001~9999	Lamps address
Information	Fixture Times	XXXXX h XX m	Total working hours
	LED Times	Led Times XXXXh XXm	Led working hours
		Reset Led Time	Reset Led Time
	Error List		Error details
	Diagnosis	BOARD 1: XX.XX%	Diagnosis
		BOARD 2: XX.XX%	
		BOARD 3: XX.XX%	
Fans Monitor		Fans Monitor	
DMX Values		DMX Values	
Personality	Pan/Tilt	Pan Reverse ON/OFF	Pan Reverse ( default OFF )
		Tilt Reverse ON/OFF	Tilt Reverse ( default OFF )
		Feedback ON/OFF	Pan/Tilt Auto Switch ( default ON )
	Dmx Input	Wired Input	Wired Input ( default )
		Wireless Input	Wireless Input
		Wireless In/XLR out	Wireless In/XLR out
	Language	English	language choice
		Chinese	
	Screen	Brightness	Brightness
		Screen Time out 0-10m	Screen Time out
Touch Screen ON/OFF		Touch Screen ( default OFF )	
Auto Screen ON/OFF		Auto Screen ( default ON )	
Manual Control	Reset	Reset ALL	
		Reset Pan/Tilt	
		Reset Colour	
		Reset Gobo	
		Reset other	
Channel		Chanel Testing	
Advanced	Calibration	Input Password XXXX	Chanel Adgusting
	Factory Default	ON/OFF	Reset to orignal parameters
	Touch Calibration		Touch screen adjusting
	Firware UP date		Firware UP date



## 8.DMX protocol

Mode 1	Mode 2	Mode 3	Fade Type	Function	Dmx Value
1	20	23	Pan	Pan	0-255
2	21	24	Pan Fime	Pan Fime	0-255
3	22	25	Tilt	Tilt	0-255
4	23	26	Tilt Fime	Tilt Fime	0-255
5	7	8	color	Whatever Position	
				Empty position	0
				White → red	1-19
				red	20
				red → green	21-39
				green	40
				green → blue	41-59
				blue	60
				blue → orange	61-79
				orange	80
				orange → pink	81-99
				pink	100
				pink → CTO	101-119
				CTO	120
				CTO → fluorescence	121-139
				fluorescence	140
				Single step rotation	
				red	141-146
				green	147-152
				blue	153-158
				orange	159-164
				pink	165-170
				CTO	171-182
fluorescence	183-188				
The color of the water					
CW, fast or slow	189-213				
stop	214-219				
CCW, slow or fast	220-243				
Random color					
Random slow color	244-247				
Random medium color	248-251				
Random fast color	252-255				
6	3	4	Cyan	Linear Cyan movement	0-255
7	4	5	Magenta	Linear Magenta movement	0-255
8	5	6	Yellow	Linear Yellow movement	0-255
9	6	7	CTO	Linear CTO movement	0-255
10	8	9	Rotation Gobo Select	Rotating gobo Select 11/9/10	
				Empty position	0-4
				Gobo 1	5-7
				Gobo 2	8-10
				Gobo 3	11-13
				Gobo 4	14-16
				Gobo 5	17-19
				Gobo 6	21-23
				Rotation – set rotation on channel 11/9/10	
				Gobo 1	24-26
				Gobo 2	27-29
				Gobo 3	30-32
				Gobo 4	33-35
				Gobo 5	36-39
				Gobo 6	40-42
				Gobo Shakes at variable speed from slow to fast 11/9/10	
				Gobo 1	43-72
Gobo 2	73-102				



Mode1	Mode2	Mode3	Fade Type	Function	Dmx Value
10	8	9	Rotation Gobo Select	Gobo 3	103-132
				Gobo 4	133-162
				Gobo 5	163-192
				Gobo 6	193-222
				Forwards gobo wheel rotation from fast to slow	223-237
				No rotation	238-240
				Backwards gobo wheel rotation from slow to fast	241-255
11	9	10	Rot. gobo indexing and rotation	Gobo indexing - set position on channel 10/8/9	
				Gobo indexing	0-255
				Gobo rotation - set position on channel 10/8/9	
				No rotation	0-2
				Forwards gobo rotation from fast to slow	3-126
				No rotation	127-129
				Backwards gobo rotation from slow to fast	130-253
12	10	11	Fine Gobo Rotation	No rotation	254-255
				Fine Gobo Rotation	0-255
13	11	12	Static gono Change	Positioning	
				Unused Range	0-9
				Gobo 1	10-19
				Gobo 2	20-29
				Gobo 3	30-39
				Gobo 4	40-49
				Gobo 5	50-59
				Gobo 6	60-69
				Gobo 7	70-79
				Shaking gobos from slow to fast	
				Gobo 1	80-99
				Gobo 2	100-119
				Gobo 3	120-139
				Gobo 4	140-159
				Gobo 5	160-179
				Gobo 6	180-199
				Gobo 7	200-219
Forwards gobo wheel rotation from fast to slow	220-236				
No rotation	237-238				
Backwards gobo wheel rotation from slow to fast	239-255				
14	15	16	Prism insertion	Prism out	0-10
				Prism indexing - set position on channel 15/16/17	11-138
				Prism rotation - set position on channel 15/16/17	139-255
15	16	17	Prism rotation	Prism indexing - set position on channel 14/15/16	
				Prism indexing	0-255
				Prism rotation - set position on channel 14/15/16	
				No rotation	0-2
				Forwards Prism rotation from fast to slow	3-126
				No rotation	127-129
				Backwards Prism rotation from slow to fast	130-253
No rotation	254-255				
16	14	15	Frost	Focus moves linearly into the light beam	0-255
17	17	18	Iris	Open → closed	0-131
				Slow pulsation fast pulsation	132-171
				Slow open, slow close- fast open, fast close	172-211
				Fast open, fast close -fast open, fast close	212-251
				Close	252-255
18	12	13	Animation	Linear Animation disk insertion	0-255
19	13	14	Animation disk rotation	Continuous Animation disk clockwise rotation at linearly variable speed from fast to slow	0-124
				Stop rotation	125-130
				Continuous Animation disk couneter-clockwise rotation at linearly variable speed from slow to fast	131-255



Mode1	Mode2	Mode3	Fade Type	Function	Dmx Value
20	18	19	Zoom	Zoom linearly moves from narrow to wide beam	0-255
		20	Zoom Fine	Fine Zoom positioning	
21	19	21	Focus	Focus moves linearly from far to near position	0-255
		22	Focus Fine	Fine focus positioning	0-255
22	1	1	Stopper/ Strobe	Close	0-3
				STROBE SLOW → FAST	4-103
				OPen	104-107
				PULSATION SLOW → FAST	108-207
				Open	208-212
				Random slow Strobe	213-225
				Random medium Strobe	226-238
				Random fast Strobe	239-251
Open	252-255				
23	2	2	Dimmer	Dimmer 0-100%	0-255
		3	Dimmer	Dimmer Fime	0-255
24	24	27	Function	Unused Range	0-9
				Reset Complete -3 sec	10-14
				Reset CMY, CTO and color wheel only-3 sec.	15-19
				Reset Other -3 sec	20-24
				Reset Pan/Tilt -3 sec	25-29
				Reset Gobo -3 sec	30-34
				Dimmer Curve 1 =linear(1 sec)	35-39
				Dimmer Curve 2 =Gamma1.5(1 sec)	40-44
				Dimmer Curve 3 =Gamma2.0(1 sec)	45-49
				Dimmer Curve 4 =S(1 sec)	50-54
				Unused Range	55-104
				Disable zoom/focuslinking-1 sec.	105-109
				Enable zoom/focus linking,near distance(5meters) (default setting)-1 sec.	110-114
				Enable zoom/focus	115-119
				Enable zoom/focus linking, far distance(12meters) - 1 sec.	120-124
				Unused Range	125-224
				Autofocus priority rotation gobo	225-229
Autofocus priority FX wheel	230-234				
autofocus priority Iris	235-239				
Unused Range	240-255				



## 9. Maintenance and cleaning

### **DANGER: Disconnect from the mains before starting any maintenance work.**

It is absolutely essential that the fixture is kept clean and that dust, dirt and smoke fluid residues must not buildup on or within the fixture. Otherwise, the fixtures light-output will be significantly reduced. Regular cleaning will not only ensure the maximum light-output, but will also allow the fixture to function reliably through out its life. A soft lint-free cloth moistened with any good glass cleaning fluid is recommended, under no circumstances should alcohol or solvents be used!

The front objective lens will require weekly cleaning as smoke-fluid tends to building up residues, reducing the light-output very quickly. The cooling-fans should be cleaned monthly.

The gobos may be cleaned with a soft brush, The interior of the fixture should be cleaned at least annually using a vacuum-cleaner or an air-jet.

There are no serviceable parts inside the device except for the lamp and the fuse.

Replacing the fuse: If the lamp burns out, the fine-wire fuse of the device might fuse, too. Only replace the fuse by a fuse of same type and rating. Before replacing the fuse, unplug mains lead.

Maintenance and maintenance of the operation, please contact the manufacturer or distributor.

## 10. Electric equipment specification

### 10.1 Electrical parameters

SOURCE: 440W White LED

POWER: 750W

VOLTAGE: AC 100-240V 50/60HZ

Color temperature: 8000K

### 10.2 Weight and dimensions

Dimensions : 543X458X566mm

NET WEIGHT: 36Kg

Dimensions (Carton package) : 657X567X661mm

WEIGHT (Carton package) : 42Kg

### 10.3 Channel Characteristics

1. Channel: 24, 24, 27DMX-512.
2. Scan: Pan 540°, Tilt 244°, Scan speed adjustable. Fixture could auto reset.
3. Colour wheel: one open + 7 colors. half-color effects, CMY function.
4. Gobo wheel: one open + 6 gobos. one, Fix gobo wheel: one open + 7 gobos.
5. Prism system: 1 rotating of 8 faces.
6. Zoom: linear amplifier.
7. Focus: linear focus with auto function.
8. Dimmer: electronic dimming, linear dimmer.
9. Strobe: electronic strobe, with strobe mode of synchronistical, pulse and random.
10. Fire wheel: fire wheel with rotation.

### 10.4 Menu Function

1. Touch screen, English/Chinese menu.



2. Each DMX Value displayable.
3. Time of automatic turning off is able to set on the display, when operating pan/tilt, Color and gobos, gobos, strobe are turn off and able to set freely.
4. Display the time using of lighting feature and lamp as well as the times of turning on for lamp.
5. You can switch on and off the lamp via the control panel or via your DMX controller. It must be noted that it has to be cold before re-stricking.
6. After the DMX signal is disconnected, the display will be bright and dark.
7. Software upgrade function.

### 10.5 light table

36° Illuminance (Lux) (Lux)	2130	532	236	132	85
8.6° Illuminance (Lux) (Lux)	28920	12517	5563	3129	2002

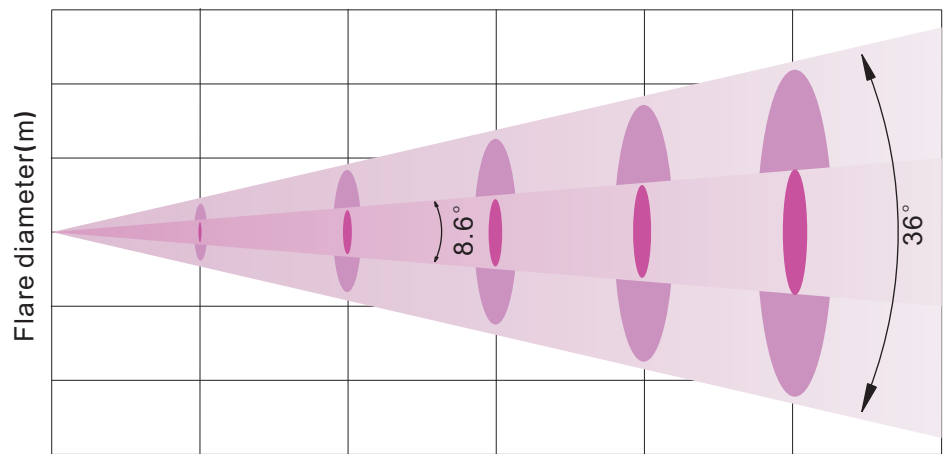

Projection distance(m)	5	10	15	20	25
The minimum Angle 8.6° Flare diameter(m)	Φ0.76	Φ1.52	Φ2.28	Φ3.04	Φ3.84
Maximum Angle 36° Flare diameter(m)	Φ3.24	Φ6.48	Φ9.72	Φ12.96	Φ16.2



## 10.6 Gobo wheel

Fix gobo wheel

Integra, Inside diameter 162mm, effective diameter 25.5mm

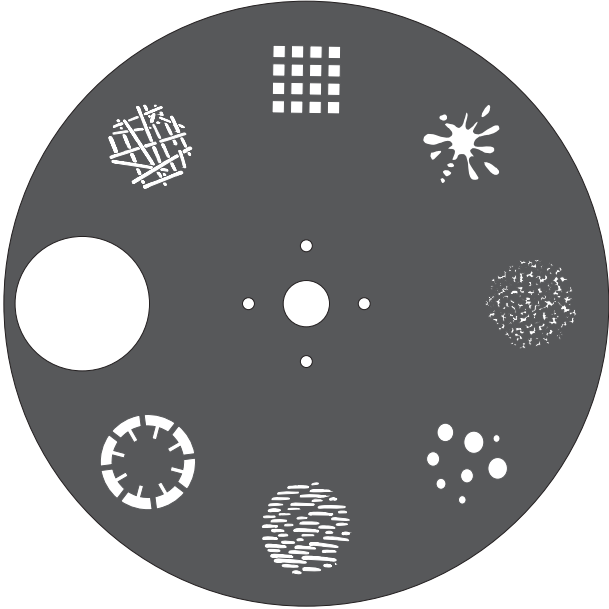

Effect wheel

Integra, Inside diameter 130mm, effective diameter 124mm

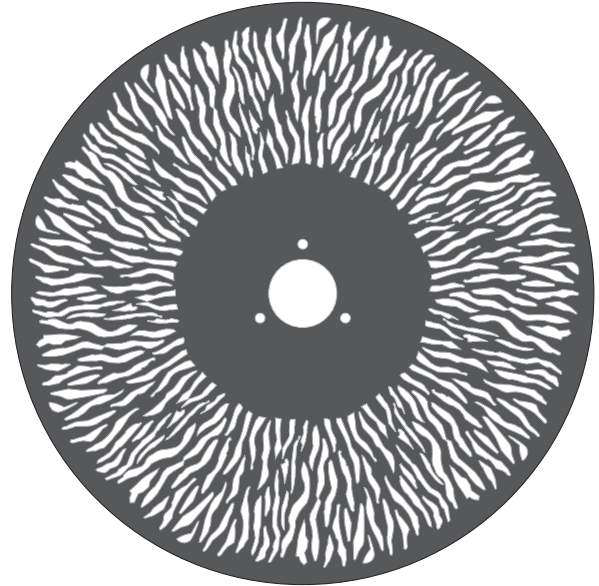

Rgobo wheel

Glass design, Inside diameter 34.7mm, effective diameter 30mm.

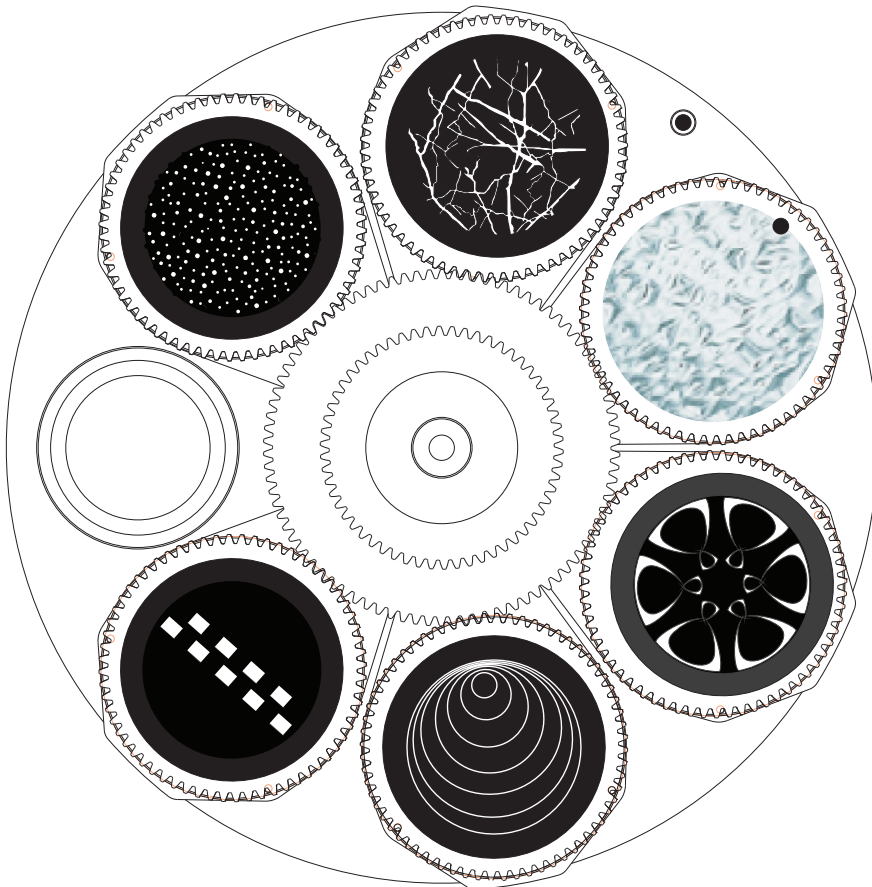



## 10.7 Color wheel

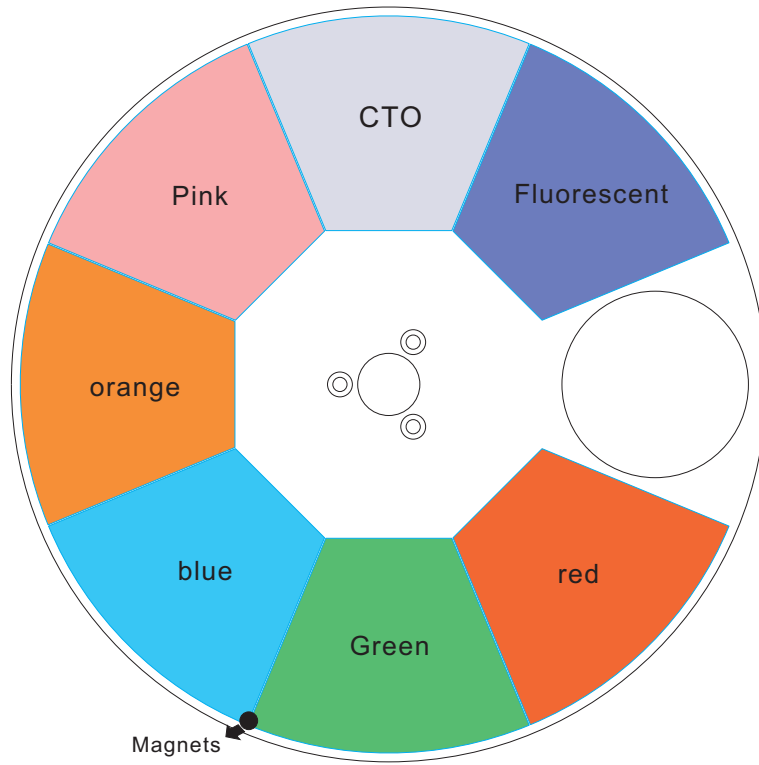



# 11. Electronic drawing

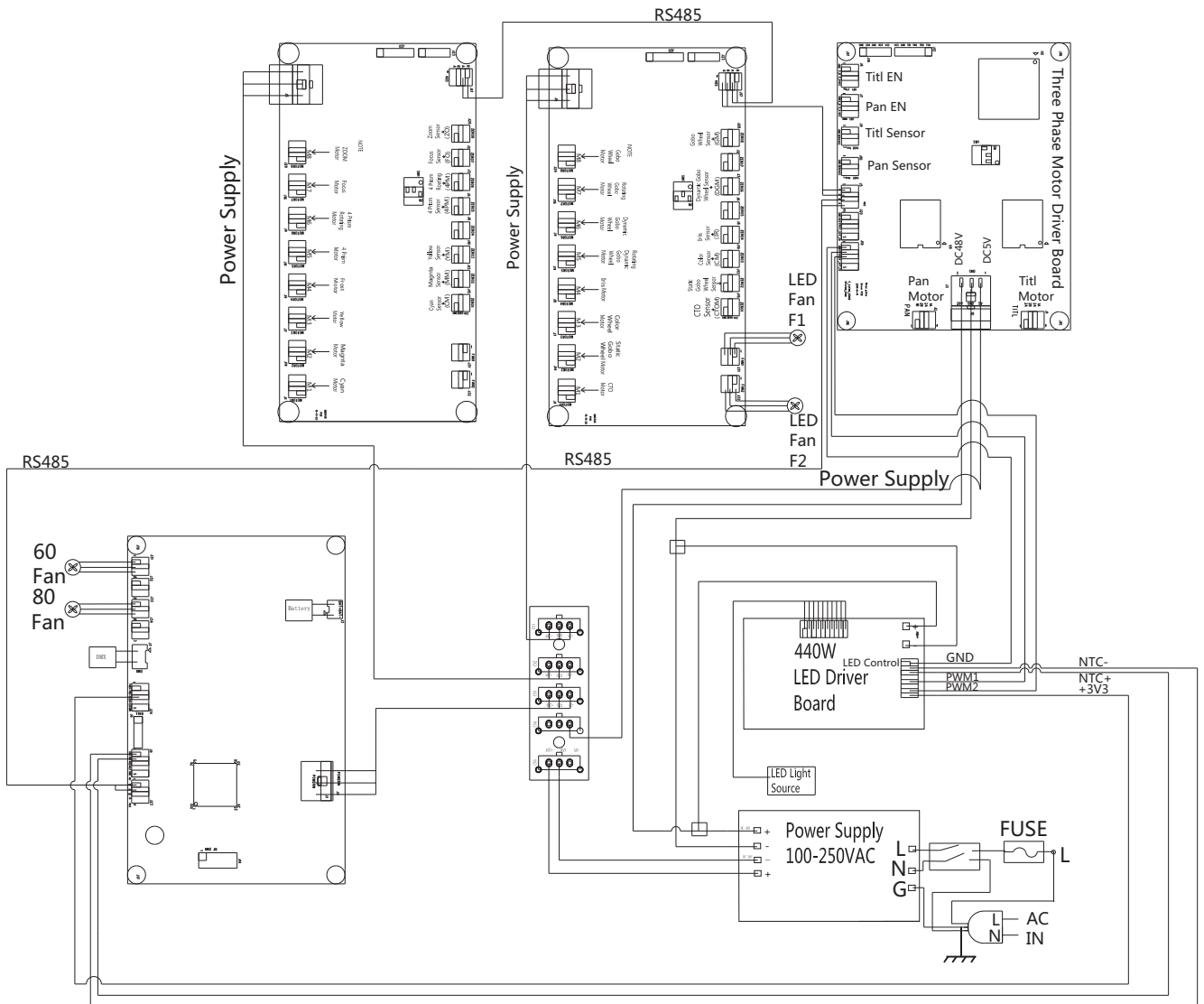

**Note: The above information is for reference only, the final interpretation is belong to manufacturer.**

